

# SECUREDGE DOUBLE CANTILEVER COPING

3'-0" O.C.

## INSTALLATION INSTRUCTIONS

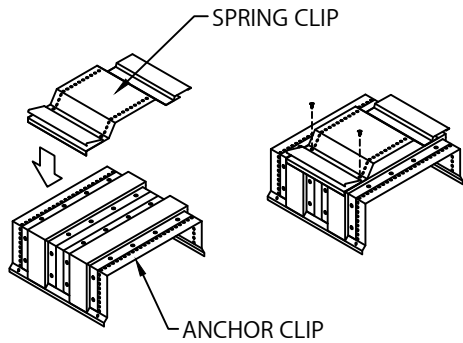

### STEP 1 - SPRING CLIP / ANCHOR CLIP

POSITION THE SPRING CLIPS IN THE CENTER OF THE ANCHOR CLIPS AND SECURE INTO PLACE WITH PROVIDED FASTENERS (SEE DETAIL A).

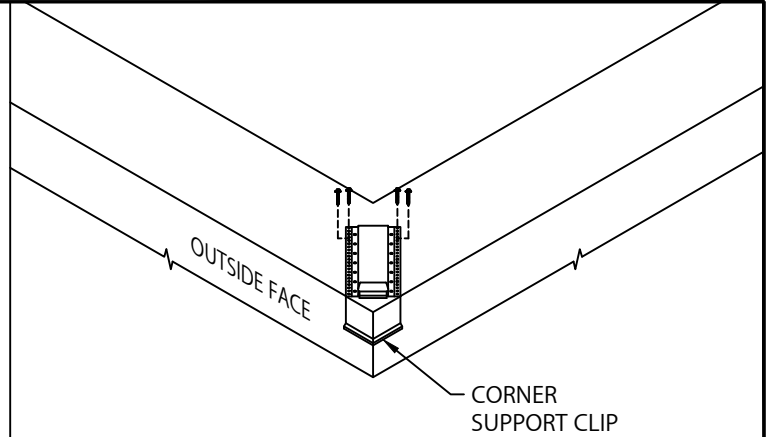

### STEP 2 - CORNER SUPPORT CLIPS

LOCATE AND FASTEN ONE GALVANIZED CORNER SUPPORT CLIP TO THE WALL AS SHOWN USING FOUR FASTENERS (PROVIDED).

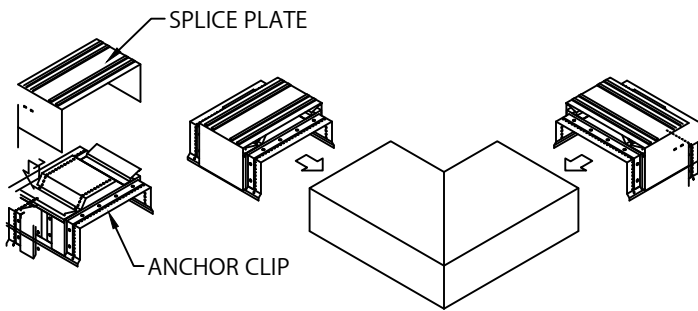

### STEP 3 - MITER SPLICE PLATES & ANCHOR CLIPS

POSITION THE SPLICE PLATE IN THE CENTER OF THE ANCHOR CLIP. INSTALL THE SPLICE PLATE AND ANCHOR CLIP ASSEMBLY HALFWAY INTO EACH END OF THE CORNER AS SHOWN

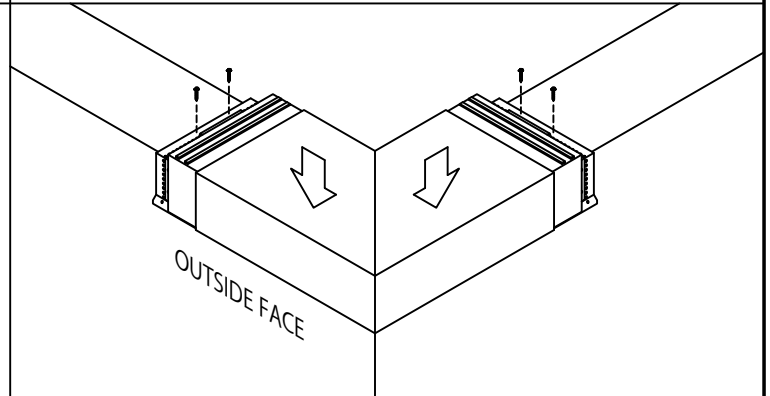

### STEP 4 - MITER

PLACE THE CORNER ASSEMBLY INTO POSITION AND SECURE AT THE EXPOSED EDGE OF THE ANCHOR CLIPS AS PER DETAIL A.

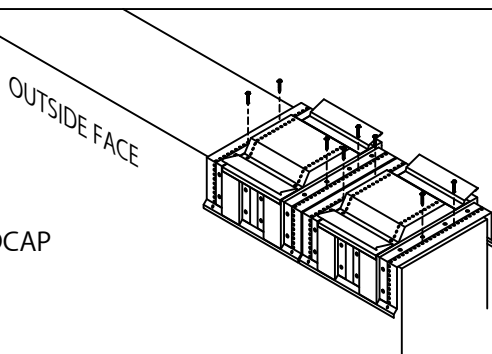

LEFT ENDCAP SHOWN

### STEP 5 - ENDCAP ANCHOR CLIPS

LOCATE AND FASTEN GALVANIZED ANCHOR CLIPS TO WALL WITH PROVIDED FASTENERS FOR SUBSTRATE (SEE DETAIL A).

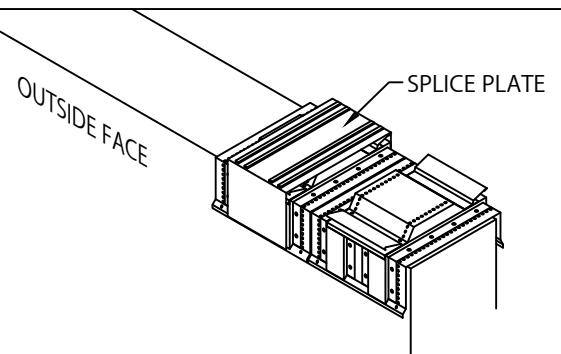

### STEP 6 - ENDCAP SPLICE PLATES

REMOVE RELEASE PAPER FROM TOP OF FACTORY APPLIED SEALANT STRIPS. PLACE SPLICE PLATE ONTO SECOND ANCHOR CLIP AS SHOWN.



Customer Service  
866-458-3537  
(Metal-Era)

DATE: 11/11/24  
DRN BY: MLM  
CKD BY: MM

SHT.# 1 OF 3  
DWG# 15111-39119

B

# SECUREDGE DOUBLE CANTILEVER COPING

3'-0" O.C.

## INSTALLATION INSTRUCTIONS

OUTSIDE FACE

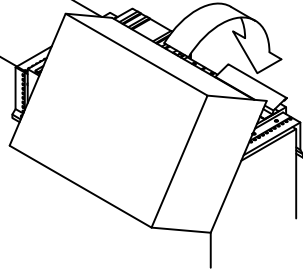

### STEP 7 - ENDCAP

HOOK OUTSIDE FACE OF ENDCAP OVER THE ANCHOR CLIPS AND ROTATE INTO PLACE. ENGAGE REAR LEG ONTO ANCHOR CLIPS BY PRESSING DOWNWARD UNTIL SNAP LOCK OCCURS.

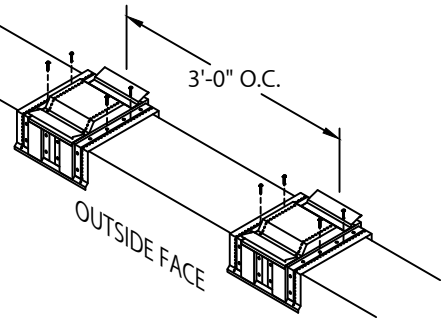

### STEP 8 - ANCHOR CLIPS

LOCATE AND FASTEN GALVANIZED ANCHOR CLIPS TO WALL AT 3'-0" CENTERS WITH PROVIDED FASTENERS FOR SUBSTRATE (SEE DETAIL A).

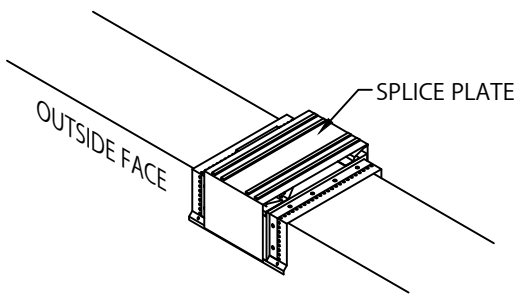

### STEP 9 - SPLICE PLATES

PLACE SPLICE PLATE ONTO ANCHOR CLIPS AT SPLICE JOINTS, 12'-0" O.C.  
NOTE: REMOVE RELEASE PAPER FROM SEALANT STRIPS.

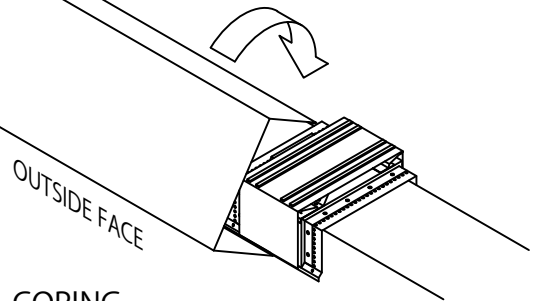

### STEP 10 - COPING

HOOK OUTSIDE FACE OF COPING OVER THE ANCHOR CLIPS AND ROTATE INTO PLACE. ENGAGE REAR LEG ONTO ANCHOR CLIPS BY PRESSING DOWNWARD UNTIL SNAP LOCK OCCURS.

OUTSIDE FACE

3/8" SPACE

### STEP 11 - COMPLETION

CONTINUE INSTALLING COPING WITH A 3/8" SPACE AT SPLICE JOINTS TO ALLOW FOR THERMAL EXPANSION. FIELD CUT WHERE NECESSARY USING FINE TOOTH HACKSAW OR SNIPS.  
NOTE: REMOVE PROTECTIVE FILM IMMEDIATELY.



Customer Service  
866-458-3537  
(Metal-Era)

DATE: 11/11/24  
DRN BY: MLM  
CKD BY: MM

SHT.# 2 OF 3  
DWG# 15111-39119

B

# SECUREDGE DOUBLE CANTILEVER COPING

3'-0" O.C.

## INSTALLATION INSTRUCTIONS

### TYPICAL COPING INSTALLATION DETAIL A

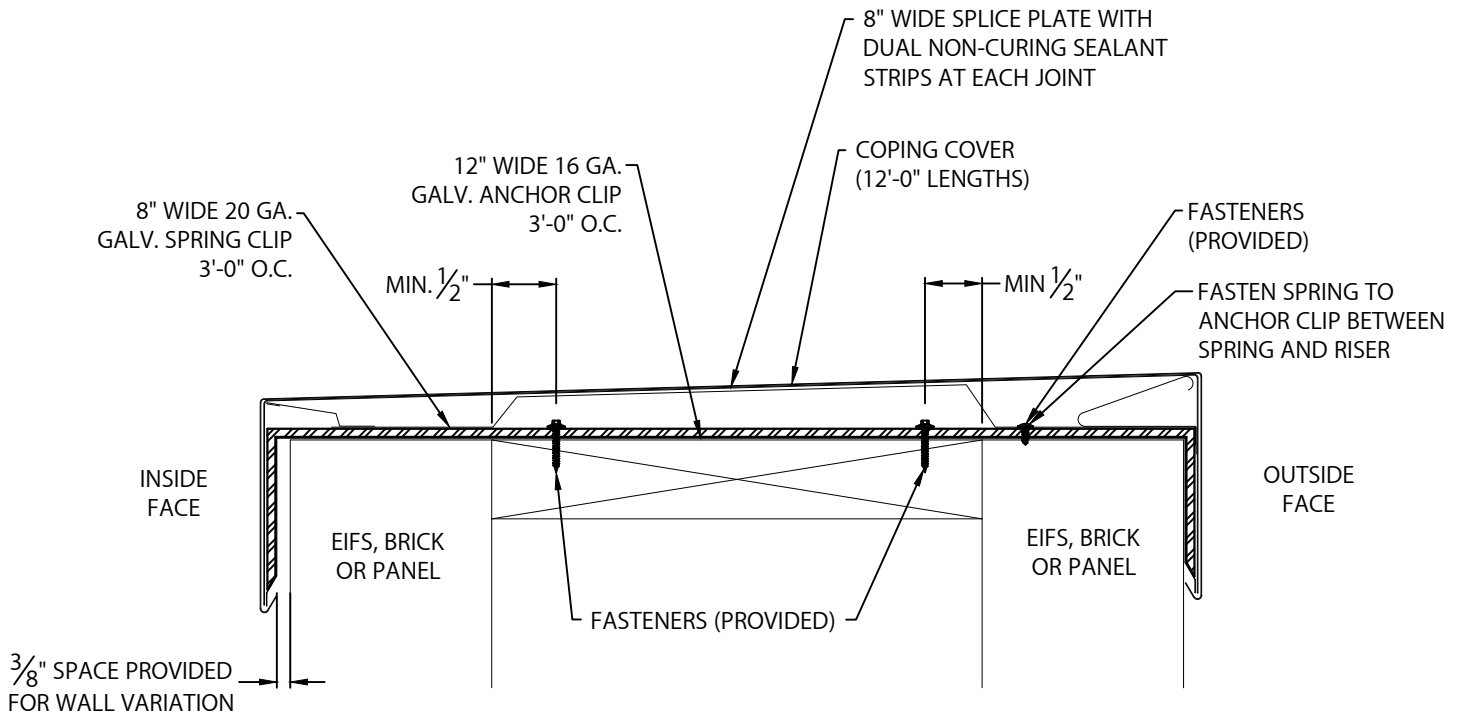

Customer Service  
866-458-3537  
(Metal-Era)

DATE: 11/11/24  
DRN BY: MLM  
CKD BY: MM

SHT.# 3 OF 3  
DWG# 15111-39119

B