



4 Commerce Way, Arden, NC 28704  
Phone: (828) 676-1700  
[www.hickmanedgesystems.com](http://www.hickmanedgesystems.com)

INSTALLATION INSTRUCTION FOR  
PERMASNAP CANTILEVER COPING  
(SADDLE VERSION)

\*MAXIMUM TESTED DIMENSIONS:  
OUTSIDE FACE: 12" | WALL WIDTH: 24" | EIFS, BRICK OR PANEL: 10" | INSIDE FACE: 4"

DATE: 07/08/24 | DRN BY: MLM | CKD BY: MM | DWG #: 64111-42990 | REV. B

## **TABLE OF CONTENTS**

<b>Overview of Coping Versions .....</b>	<b>Page 3</b>
<b>Substrate and Fastener Information .....</b>	<b>Page 4</b>
<b>Anchor Clip Spacing .....</b>	<b>Page 4</b>
<b>Standard Installation Steps .....</b> <b>(Including Standard Accessories)</b>	<b>Page 5-7</b>
<b>Radius Coping Installation Steps .....</b>	<b>Page 8</b>

# PERMASNAP CANTILEVER COPING

SADDLE VERSIONS

## TAPERED

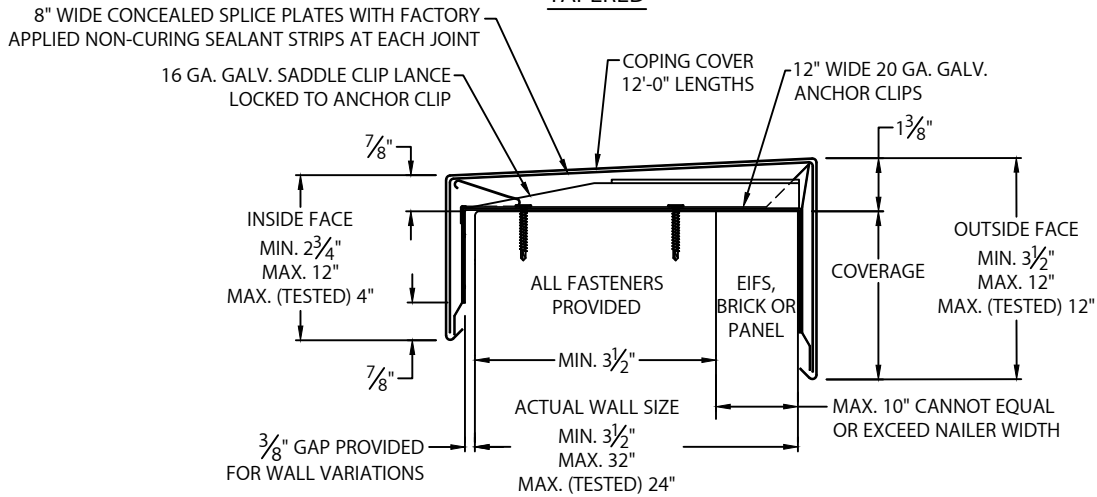

## FLAT

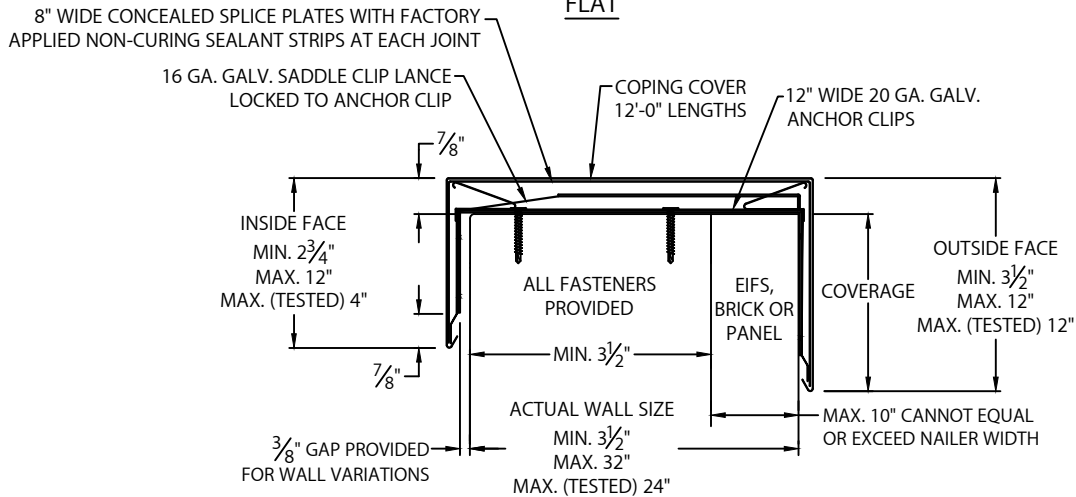

## EXISTING SLOPE

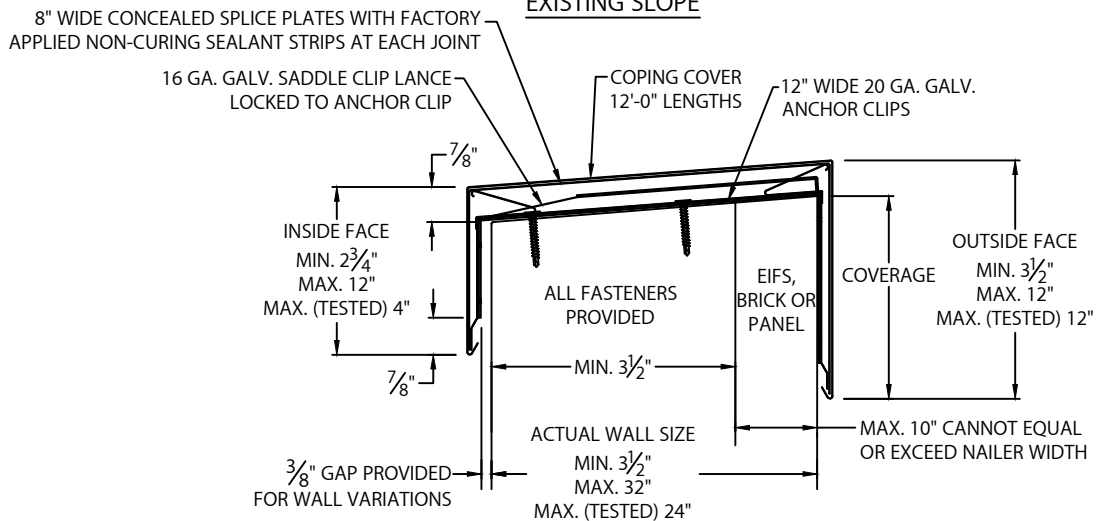

# HICKMAN

Hickman Edge Systems  
4 Commerce Way  
Arden, NC 28704  
Phone: 828-676-1700  
www.hickmanedgesystems.com

DATE: 07/08/24

DRN BY: MLM

CKD BY: MM

SHT.# 3 OF 8

DWG# 64111-42990

B

# PERMASNAP CANTILEVER COPING

SADDLE VERSIONS

## FASTENERS AND ANCHOR CLIP INFORMATION

### COPING SUBSTRATE AND FASTENERS

THIS COPING CAN BE INSTALLED ON THE FOLLOWING SUBSTRATE USING THE FASTENERS PROVIDED BY THE MANUFACTURER .  
TYPICAL INSTALLATION ON WOOD SUBSTRATE. (TAPERED VERSION SHOWN)

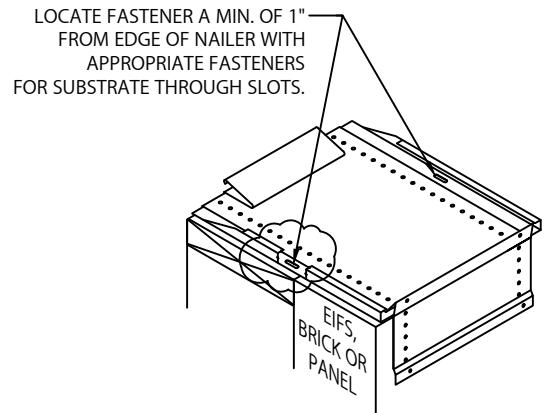
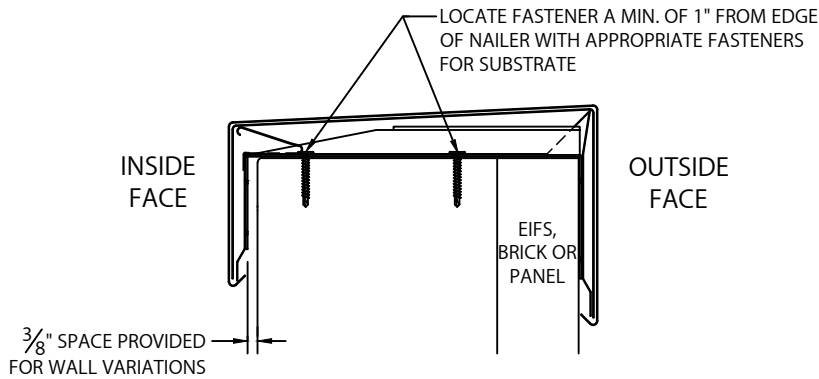

SUBSTRATE	TOP FASTENERS
WOOD, MASONRY AND METAL	#14 X 1-1/2" PROFILER

NOTE: ALTERNATIVE OR UNIVERSAL FASTENERS MAY BE PROVIDED AS A SUBSTITUTE FOR THE FASTENERS LISTED BASED ON AVAILABILITY. ANY SUBSTITUTE FASTENER PROVIDED WILL BE OF EQUAL OR GREATER EQUIVALENCY.

### COPING ANCHOR CLIPS AND SPACING

ANCHOR CLIP SPACING IS DETERMINED BY THE MANUFACTURER BASED ON WALL SIZE.

#### ANCHOR CLIP DETAIL FOR WALLS GREATER THAN 14"

NOTE: ALL RADIUS COPING WILL HAVE DOUBLE SPRING ANCHOR CLIPS

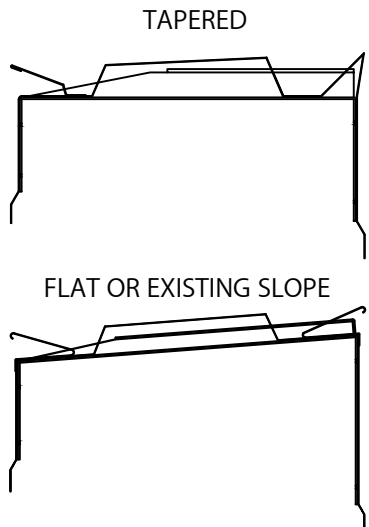

#### ANCHOR CLIP SPACING FOR STRAIGHT LENGTHS

WALL SIZE	ANCHOR CLIP SPACING
0" THRU 32"	3' - 0" O.C.

#### ANCHOR CLIP AND SPLICE PLATE INFORMATION FOR RADIUS COPING

WALL WIDTH	SPLICE PLATE WIDTH	ANCHOR CLIP WIDTH	ANCHOR CLIP SPACING

# HICKMAN

Hickman Edge Systems  
4 Commerce Way  
Arden, NC 28704  
Phone: 828-676-1700  
www.hickmanedgesystems.com

DATE: 07/08/24  
DRN BY: MLM  
CKD BY: MM

SHT.# 4 OF 8  
DWG# 64111-42990

B

# PERMASNAP CANTILEVER COPING

SADDLE VERSION

## INSTALLATION INSTRUCTIONS

IMPORTANT: PRIOR TO INSTALLATION, READ INSTRUCTIONS CAREFULLY.

NOTE: POSITION ROOF MEMBRANE ON TOP OF THE WALL COVERING THE TREATED WOOD NAILER(S) OR SUBSTRATE COMPLETELY. ALLOW 1/2" MINIMUM EXCESS MEMBRANE BEYOND NAILER WHERE APPLICABLE. NRCA REQUIREMENT.

CAUTION: INSTALL MITERS FIRST!

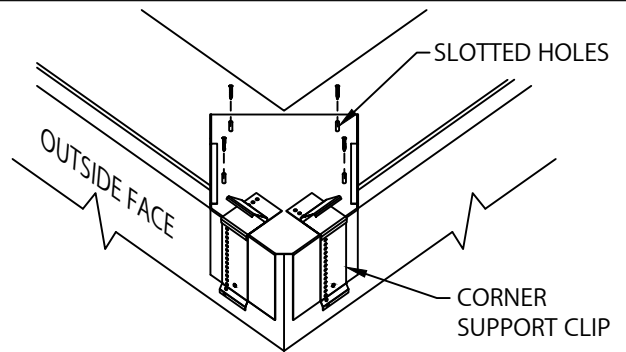

### STEP 1 - CORNER SUPPORT CLIPS

LOCATE AND FASTEN THRU SLOTTED HOLES ONE GALVANIZED CORNER SUPPORT CLIP TO THE WALL AS SHOWN USING FOUR FASTENERS PROVIDED FOR SUBSTRATE, AS PER DETAIL A.

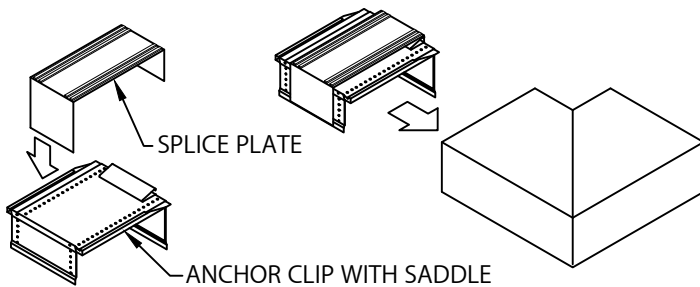

### STEP 3 - MITER

PLACE THE CORNER ASSEMBLY INTO POSITION AND SECURE AT THE EXPOSED EDGE OF THE ANCHOR CLIPS AS PER DETAIL A.

NOTE: REMOVE PROTECTIVE PLASTIC FILM IMMEDIATELY.

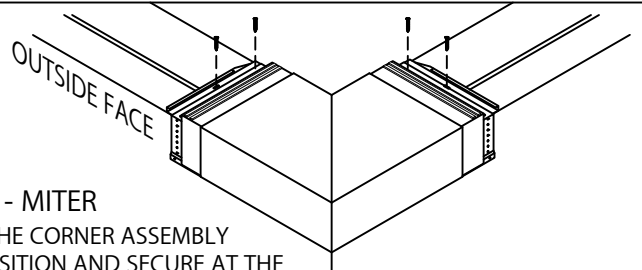

### STEP 2 - MITER SPLICE PLATES & ANCHOR CLIPS

REMOVE RELEASE PAPER FROM SPLICE PLATE SEALANT STRIPS. POSITION THE SPLICE PLATE IN THE CENTER OF THE ANCHOR CLIP. INSTALL THE SPLICE PLATE AND ANCHOR CLIP ASSEMBLIES HALFWAY INTO EACH END OF THE CORNER MITER AS SHOWN.

### STEP 4 - ENDCAP ANCHOR CLIPS

LOCATE AND FASTEN TWO GALVANIZED ANCHOR CLIPS TO THE WALL WITH PROVIDED FASTENERS FOR SUBSTRATE, AS SHOWN IN DETAIL A.

### STEP 5 - ENDCAP SPLICE PLATE

REMOVE RELEASE PAPER FROM THE TOP OF THE FACTORY APPLIED SEALANT STRIPS. PLACE THE SPLICE PLATE ONTO THE SECOND ANCHOR CLIP AS SHOWN.

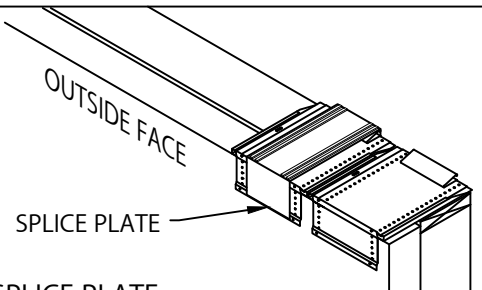
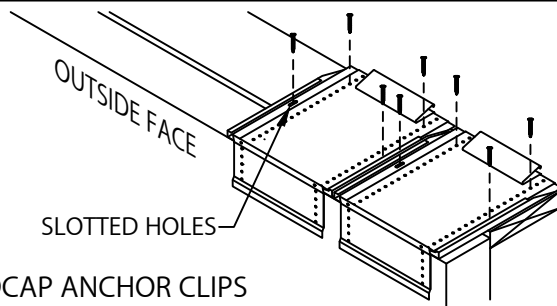

### STEP 6 - ENDCAP

HOOK OUTSIDE FACE OF ENDCAP OVER THE ANCHOR CLIPS AND ROTATE INTO PLACE. ENGAGE REAR LEG ONTO ANCHOR CLIPS BY PRESSING DOWNWARD UNTIL SNAP LOCK OCCURS.

NOTE: REMOVE PROTECTIVE PLASTIC FILM IMMEDIATELY.

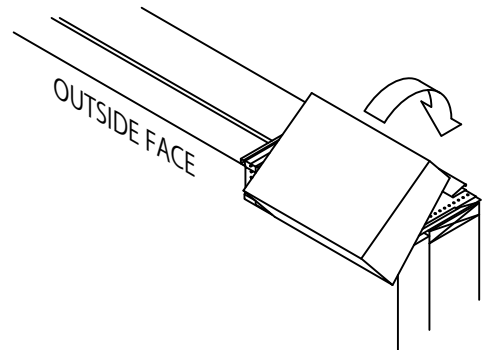

# HICKMAN

Hickman Edge Systems  
4 Commerce Way  
Arden, NC 28704  
Phone: 828-676-1700  
www.hickmanedgesystems.com

DATE: 07/08/24

DRN BY: MLM

CKD BY: MM

SHT.# 5 OF 8

DWG# 64111-42990

B

# PERMASNAP CANTILEVER COPING

SADDLE VERSION

## INSTALLATION INSTRUCTIONS

### STEP 7 - ENDWALL FLASHING COPING VERSIONS STEP 7 - 8

NOTE: WITH THIS ENDWALL FLASHING THERE ARE TWO ANCHOR CLIPS AND ONE WITH A SPLICE PLATE.

HOOK OUTSIDE FACE OF ENDCAP OVER THE ANCHOR CLIPS AND ROTATE INTO PLACE. ENGAGE REAR LEG ONTO ANCHOR CLIPS BY PRESSING DOWNWARD UNTIL SNAP LOCK OCCURS.

NOTE: REMOVE PROTECTIVE PLASTIC FILM IMMEDIATELY.

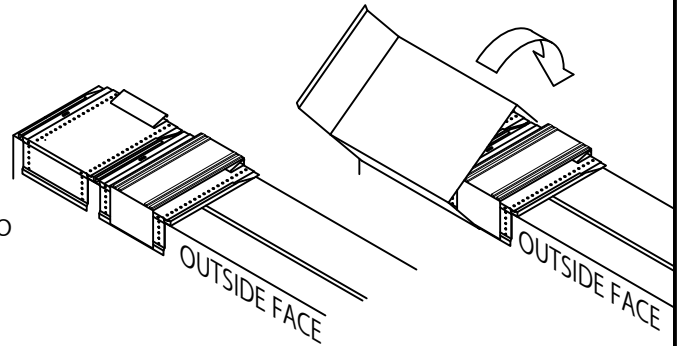

### STEP 8 - ENDWALL FLASHING

FASTEN TO WALL USING APPROPRIATE FASTENERS AS SHOWN. APPLY NON-CURING SEALANT (BY OTHERS) TO CAULK CUP AT TOP OF 3" FLANGE.

NOTE: REMOVE PROTECTIVE PLASTIC FILM IMMEDIATELY.

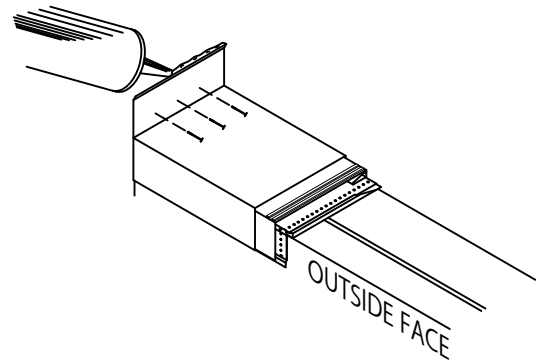

### STEP 9 - ENDWALL FLASHING SPLICE PLATE VERSION STEPS 9 - 10

NOTE: WITH THE ENDWALL FLASH SPLICE PLATE VERSION THERE IS ONE ANCHOR CLIP.

PLACE ENDWALL FLASHING ON TOP OF ANCHOR CLIP. REMOVE RELEASE PAPER FROM FACTORY APPLIED SPLICE PLATE SEALANT STRIPS. FASTEN TO WALL USING APPROPRIATE FASTENERS AS SHOWN. APPLY NON-CURING SEALANT (BY OTHERS) TO CAULK CUP AT TOP OF 3" FLANGE.

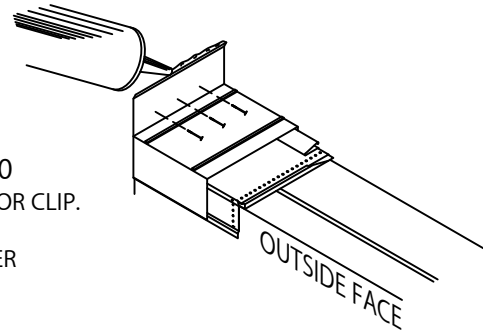

### STEP 10 - COPING

HOOK OUTSIDE FACE OF COPING OVER THE ANCHOR CLIP / ENDWALL FLASHING AND ROTATE INTO PLACE. ENGAGE REAR LEG ONTO ANCHOR CLIP BY PRESSING DOWNWARD UNTIL SNAP LOCK OCCURS.

NOTE: REMOVE PROTECTIVE PLASTIC FILM IMMEDIATELY.

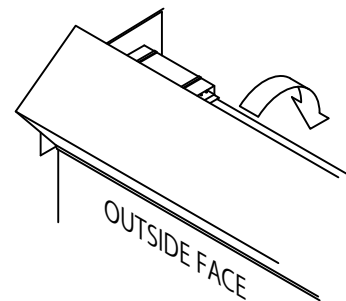

# HICKMAN

Hickman Edge Systems  
4 Commerce Way  
Arden, NC 28704  
Phone: 828-676-1700  
[www.hickmanedgesystems.com](http://www.hickmanedgesystems.com)

DATE: 07/08/24

DRN BY: MLM

CKD BY: MM

SHT.# 6 OF 8

DWG# 64111-42990

B

# PERMASNAP CANTILEVER COPING

SADDLE VERSION

INSTALLATION INSTRUCTIONS

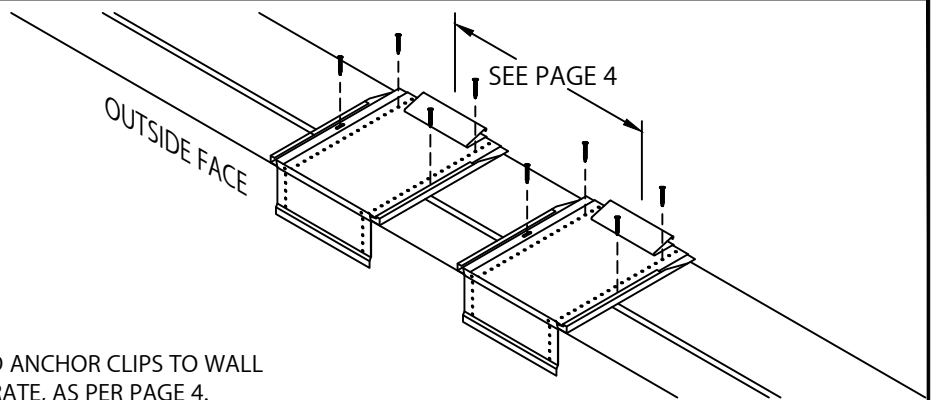

## STEP 11 - ANCHOR CLIPS

LOCATE OVER MEMBRANE AND FASTEN GALVANIZED ANCHOR CLIPS TO WALL ON CENTER WITH PROVIDED FASTENERS FOR SUBSTRATE, AS PER PAGE 4.

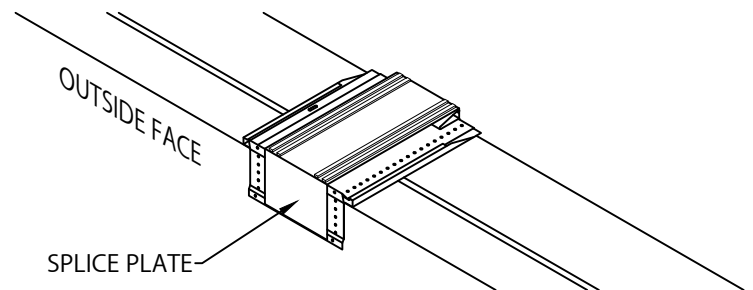

## STEP 12 - SPLICE PLATES

PLACE SPLICE ONTO ANCHOR CLIPS AT SPLICE JOINTS 12'-0" O.C.

NOTE: REMOVE RELEASE PAPER FROM SEALANT STRIPS.

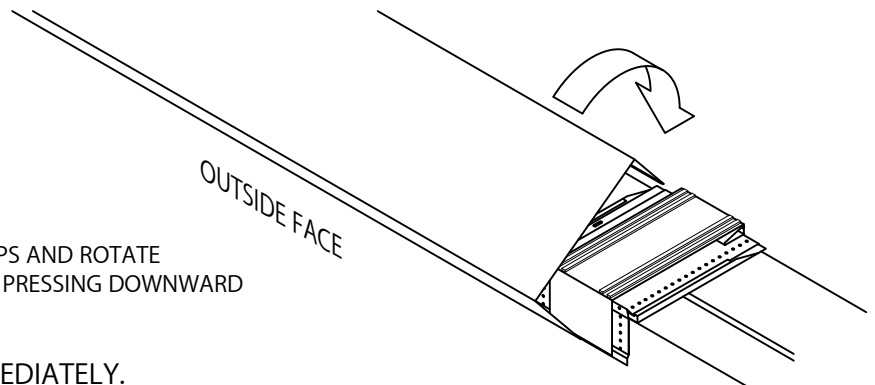

## STEP 13 - COPING

HOOK OUTSIDE FACE OF COPING OVER THE ANCHOR CLIPS AND ROTATE INTO PLACE. ENGAGE REAR LEG ONTO ANCHOR CLIPS BY PRESSING DOWNWARD UNTIL SNAP LOCK OCCURS.

NOTE: REMOVE PROTECTIVE PLASTIC FILM IMMEDIATELY.

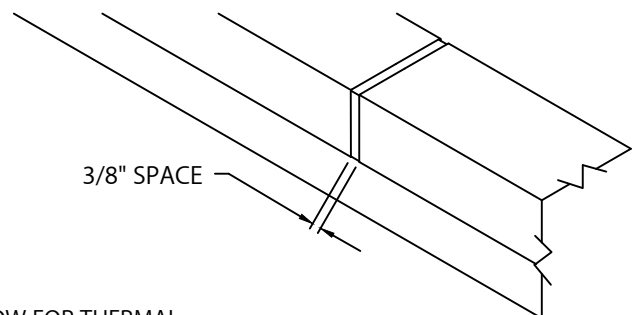

## STEP 14 - COMPLETION

CONTINUE INSTALLING COPING WITH A 3/8" SPACE AT SPLICE JOINTS TO ALLOW FOR THERMAL EXPANSION. FIELD CUT WHERE NECESSARY USING A FINE TOOTH HACKSAW OR SNIPS.

# HICKMAN

Hickman Edge Systems  
4 Commerce Way  
Arden, NC 28704  
Phone: 828-676-1700  
www.hickmanedgesystems.com

DATE: 07/08/24

DRN BY: MLM

CKD BY: MM

SHT.# 7 OF 8

DWG# 64111-42990

B

# PERMASNAP CANTILEVER COPING

SADDLE VERSION

INSTALLATION INSTRUCTIONS

## PERMASNAP CANTILEVER RADIUS COPING INSTRUCTIONS

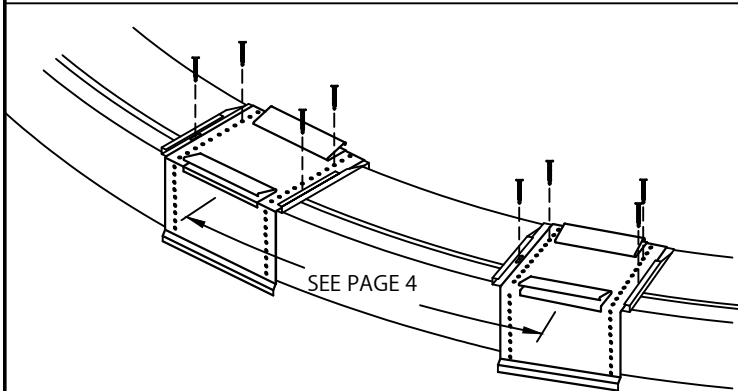

### STEP 1 - ANCHOR CLIPS

NOTE: RADIUS WILL HAVE DOUBLE SPRING ANCHOR CLIPS. ANCHOR CLIPS WIDTH WILL BE DETERMINED BY RADIUS SIZE AND MATERIAL. LOCATE AND FASTEN ANCHOR CLIPS WITH PROVIDED FASTENERS FOR SUBSTRATE. SEE PAGE 4, FOR ANCHOR CLIP SPACING.

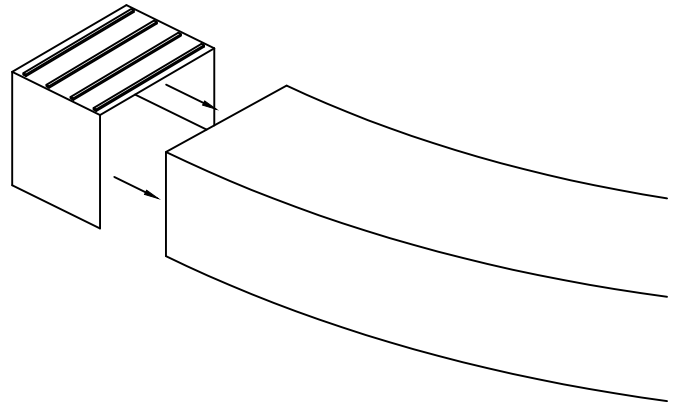

### STEP 2 - SPLICE PLATES

NOTE: ANCHOR CLIPS WIDTH WILL BE DETERMINED BY RADIUS SIZE AND MATERIAL. ALL SPLICE PLATES ARE PROVIDED. REMOVE RELEASE PAPER LEFT TWO SEALANT STRIPS. INSERT SPLICE PLATE HALFWAY INTO THE RIGHT END OF RADIUS SECTION.

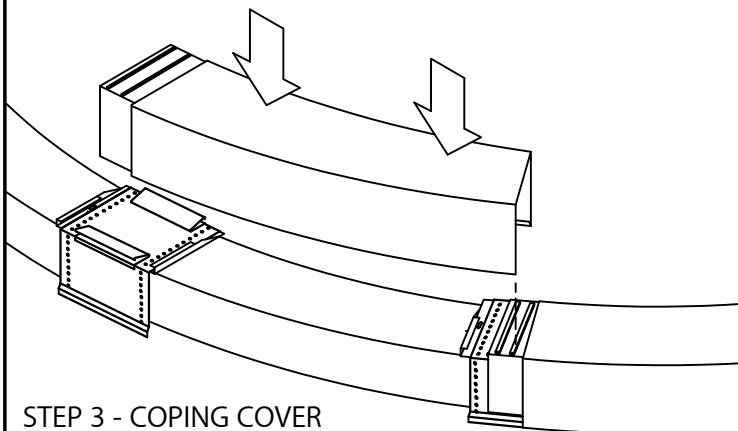

### STEP 3 - COPING COVER

NOTE: 4'-0" O.C. SHOWN.  
REMOVE RELEASE PAPER FROM RIGHT TWO FACTORY APPLIED SEALANT STRIPS ON THE SPLICE PLATE ON THE COPING SECTION. INSTALL RADIUS COPING SECTIONS FROM LEFT TO RIGHT. PLACE COPING INTO POSITION AND PRESS DOWNWARD UNTIL SNAP-LOCK OCCURS.

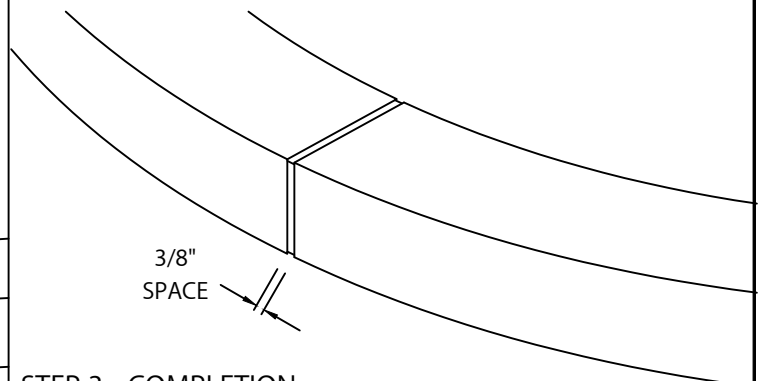

### STEP 3 - COMPLETION

USING RADIUS SECTIONS TO COVER ALL EXPOSED CLIPS / SPLICES, CUT TO LENGTH AS NEEDED USING A FINE TOOTH HACKSAW, SNIPS, OR CUT-OFF WHEEL LEAVING A CLEAN EDGE. BE SURE TO LEAVE A 3/8" SPACE AT EACH JOINT.

NOTE: REMOVE PROTECTIVE FILM IMMEDIATELY.

# HICKMAN

Hickman Edge Systems  
4 Commerce Way  
Arden, NC 28704  
Phone: 828-676-1700  
www.hickmanedgesystems.com

DATE: 07/08/24

DRN BY: MLM

CKD BY: MM

SHT.# 8 OF 8

DWG# 64111-42990

B