



SECUREDGE THRU-WALL SCUPPER

STYLE 1 POP-RIVETED RAISED COLLECTOR BOX

NOTES

- Product should be installed per provided installation instructions

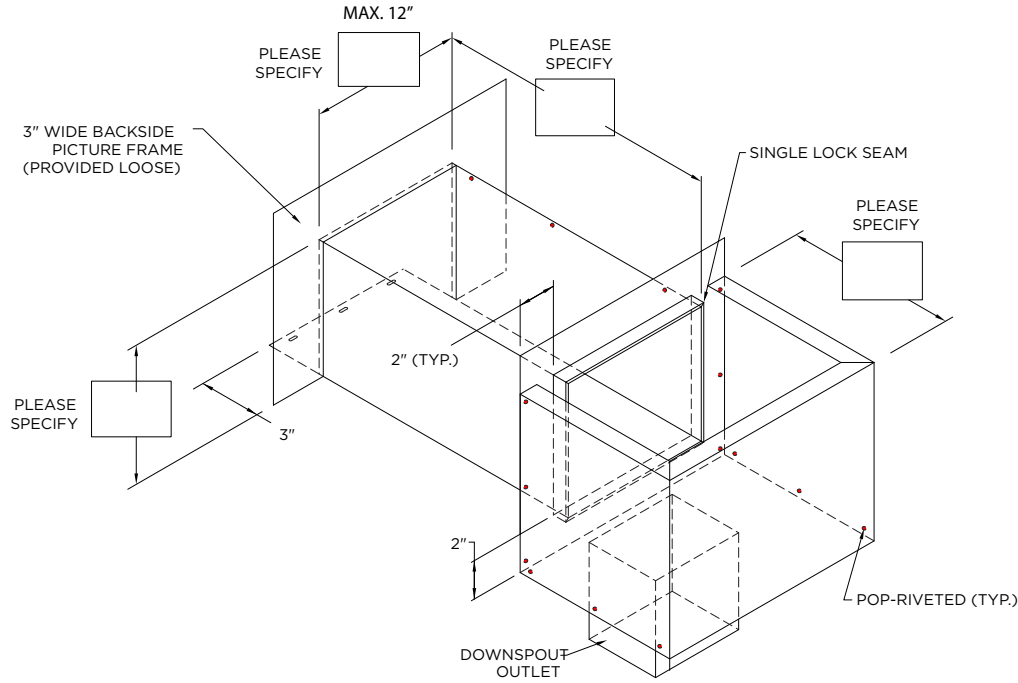

PROJECT INFO

Project Name: _____

Architect: _____

Roofing Contractor: _____

Project Type:

By selecting this box you have verified and confirmed that dimensions, sizes, and quantities are correct. All products will be installed in strict accordance with printed instructions.

Date: _____

Customer Service
866-458-3537
(Metal-Era)

SHT #: _____ of _____

DATE: **11/20/24**

DRN BY: **JJC**

CKD BY: **MM**

DWG # : 15018-13084

REV: **D**

DIMENSIONS

PLEASE FILL OUT DIMENSIONS ON DRAWING

MATERIAL

- 24 Ga. Galv. Steel
- 22 Ga. Galv. Steel
- .040" Aluminum
- .050" Aluminum
- OTHER: _____

Color: _____

Finish: _____

QUANTITIES

_____ Amount Required

Downspout Size _____ x _____