

OUTSIDE MITER

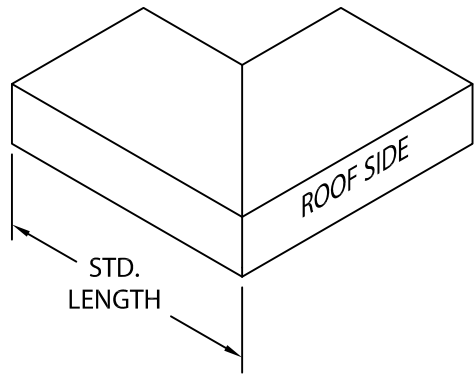

INSIDE MITER

MITER STANDARD LEG LENGTH:
WALL SIZE + 10 3/8" = LENGTH

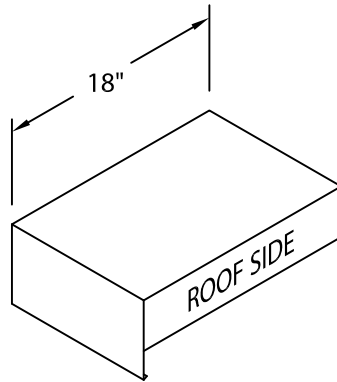

ENDCAP
(LEFT HAND SHOWN)

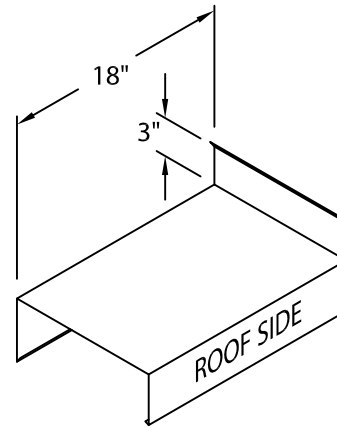

ENDWALL FLASHING
COPING VERSION
(RIGHT HAND SHOWN)

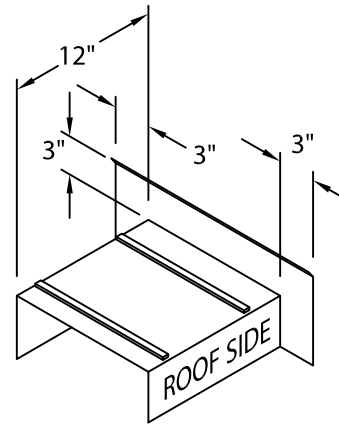

ENDWALL FLASHING
SPLICE PLATE VERSION
(RIGHT HAND SHOWN)
(AVAILABLE ONLY IN
.040" WELDED, PAINTED
TO MATCH COPING)

NOTES

Additional accessories are available including:

- Transition Miters
- Straight Transition Miters
- "T" Miters
- "Z" Miters
- Step-up Miters
- Peak / Valley Miters
- Pilaster Caps
- Radius Coping

For additional accessory requirements, attach sketches or call manufacturer for assistance.

SHT# 2 of 2

DATE: 08/10/22

DRN BY: JJC

CKD BY: MM

DWG #: 64011-36828

REV: A

Hickman Edge Systems
4 Commerce Way
Arden, NC 28704
Phone: 828-676-1700
www.hickmanedgesystems.com