



# VERSITRIM COPING

## EXISTING SLOPE

### \* NOTES

- Oil canning can occur on larger face heights and wall widths; recommend 22 Ga., .050" or .063" Aluminum for face height over 8" or wall width over 12".

- 24 Ga. and .040" Aluminum covers available for wall sizes 3.5" to 24" ONLY

- Unless otherwise noted, fabrication of miters and accessories are furnished standard utilizing a non-penetrating quicklock joint, then factory sealed watertight

- Welded accessories require a minimum material thickness of .050" Aluminum

- For non-90 miters, see separate print approval

- Product should be installed per provided installation instructions

- ANSI/SPRI/FM 4435/ES-1 test pressures up to 226 psf (Horizontal) and 391 psf (Vertical)

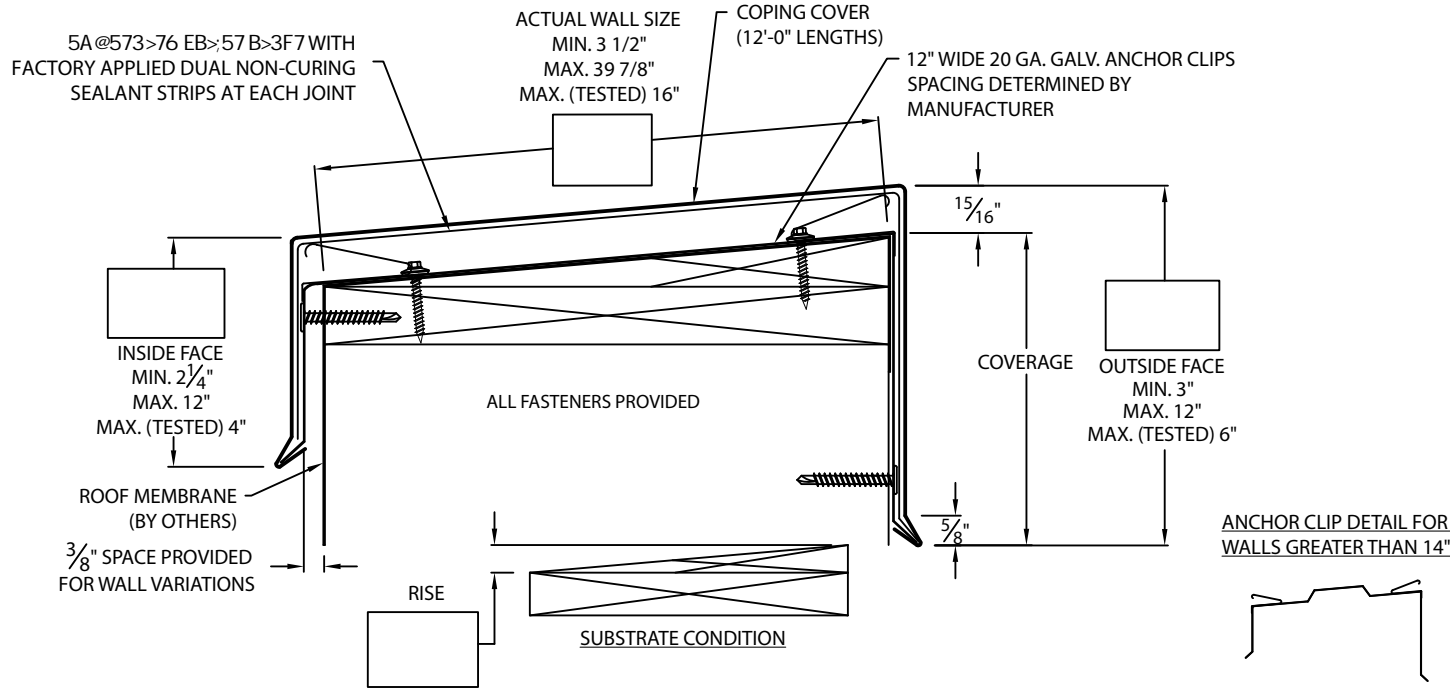

### PROJECT INFO

Project Name: \_\_\_\_\_

Architect: \_\_\_\_\_

Roofing Contractor: \_\_\_\_\_

#### Project Type:

By selecting this box you have verified and confirmed that dimensions, sizes, and quantities are correct. All products will be installed in strict accordance with printed instructions.

Date: \_\_\_\_\_

Customer Service  
800-558-2162  
(Metal-Era)

SHT #: \_\_\_\_\_ of \_\_\_\_\_

DATE: **09/19/24**

DRN BY: **JJC**

CKD BY: **MM**

DWG #: **18011-19347**

REV: **J**

### APPROVALS\*

**ANSI/SPRI/FM 4435/ES-1**  
Test Pressures listed in notes



### MATERIAL\*

- 24 Ga. Galv. Steel
  - 22 Ga. Galv. Steel
  - .040" Aluminum
  - .050" Aluminum
  - .063" Aluminum
  - OTHER: \_\_\_\_\_
- Color: \_\_\_\_\_
- Finish: \_\_\_\_\_
- Substrate: (For Top Fasteners)
- Wood
  - Masonry
  - Metal
- if substrate is not given, wood fasteners will be provided.

### QUANTITIES

\_\_\_\_\_ Lineal Feet (12'-0" Lengths)

\_\_\_\_\_ Outside Miter (90°)

\_\_\_\_\_ Inside Miter (90°)

\_\_\_\_\_ Right Endcaps

\_\_\_\_\_ Left Endcaps

Accessory Type\* :  Quicklock (Default)  Welded (Surcharge)

\_\_\_\_\_ Right Endwall Flashing (Coping Version)

\_\_\_\_\_ Left Endwall Flashing (Coping Version)

\_\_\_\_\_ Right Endwall Flashing (Splice Plate Version)

\_\_\_\_\_ Left Endwall Flashing (Splice Plate Version)

**VERSITRIM COPING**  
STANDARD ACCESSORIES

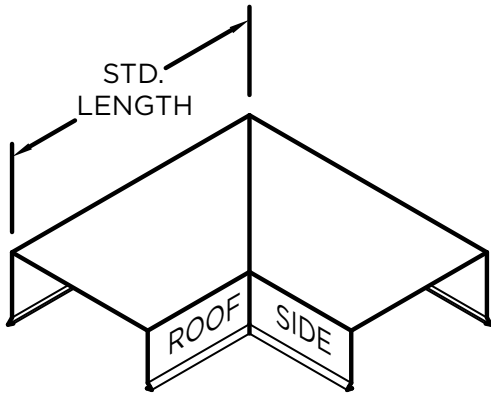

OUTSIDE MITER

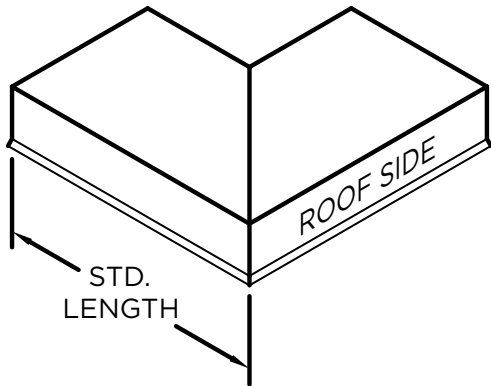

INSIDE MITER

MITER STANDARD LEG LENGTH:  
WALL SIZE +  $9 \frac{5}{8}$ " = LENGTH

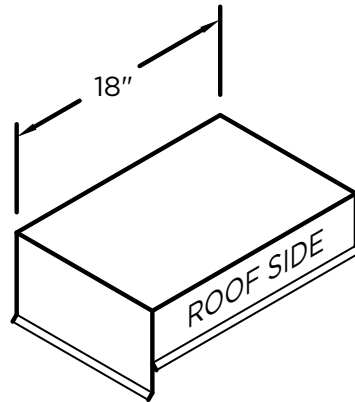

ENDCAP  
(LEFT HAND SHOWN)

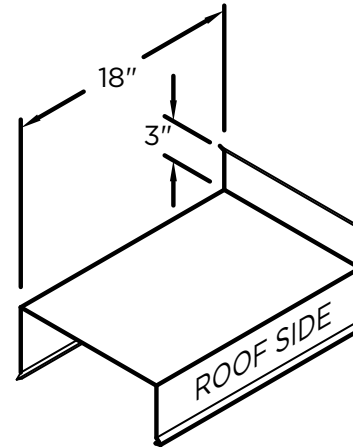

ENDWALL FLASHING  
COPING VERSION  
(RIGHT HAND SHOWN)

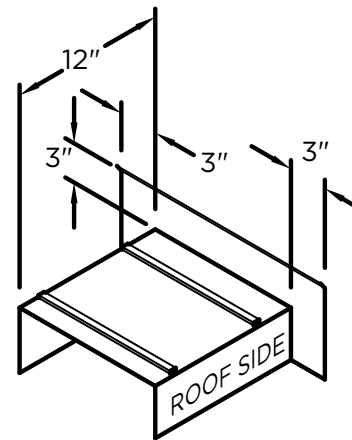

ENDWALL FLASHING  
SPLICE PLATE VERSION  
(RIGHT HAND SHOWN)  
(AVAILABLE ONLY IN  
.040" WELDED, PAINTED  
TO MATCH COPING)

**NOTES**

Additional accessories are available including:

- Transition Miters
- Straight Transition Miters
- "T" Miters
- "Z" Miters
- Step-up Miters
- Peak / Valley Miters
- Pilaster Caps
- Radius Coping
- Arched Coping

For additional accessory requirements, attach sketches or call manufacturer for assistance.

SHT #: \_\_\_\_ of \_\_\_\_

DATE: **09/19/24**

DRN BY: **JJC**

CKD BY: **MM**

DWG #: **18011-19347**

REV: **J**

Customer Service  
800-558-2162  
(Metal-Era)