

## HALF ROUND GUTTER NON-VERTICAL FASCIA WITH "V" SUPPORT

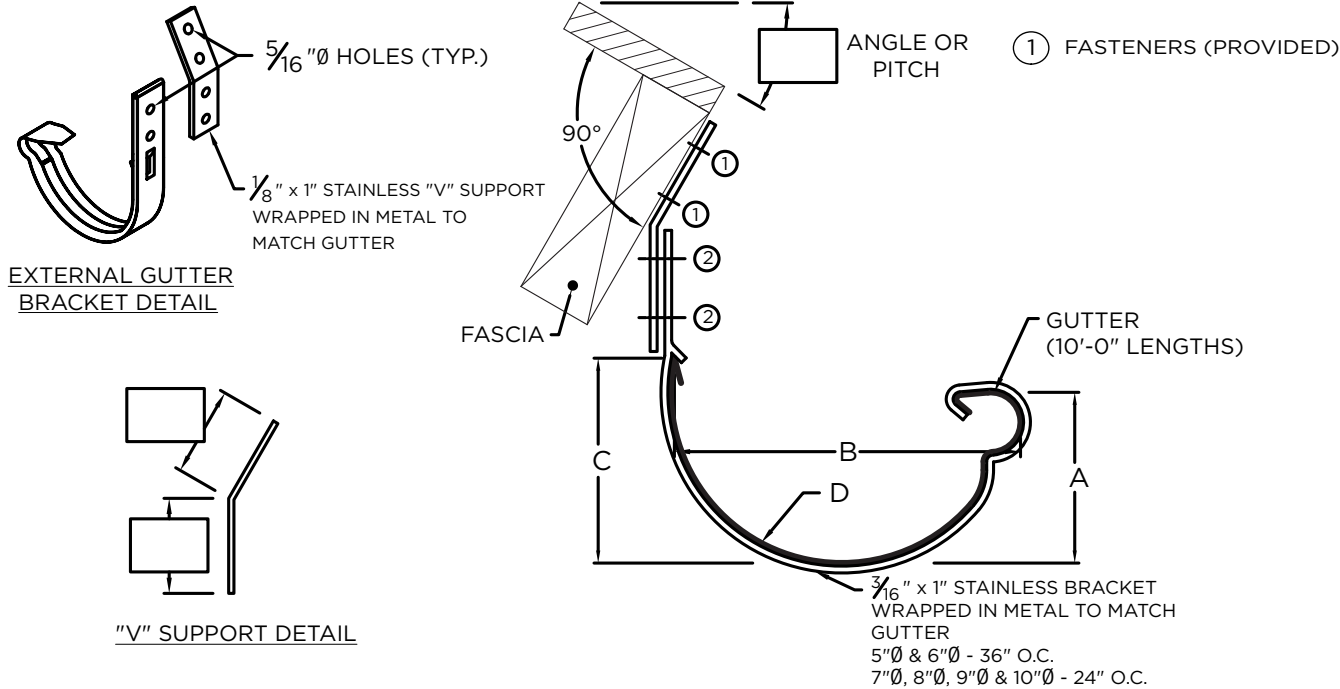

### \* NOTES

- .050" provided with splice plates
- 24 ga., 22 ga., .032", .040" all need field notched lap joints
- 5" not available in 22 ga. steel or .050" aluminum
- Stainless steel pop rivets provided
- Unless otherwise noted, fabrication of miters and accessories are furnished standard utilizing a non-penetrating quicklock joint, then factory sealed watertight
- Welded accessories require minimum material thickness of .050"
- For non-90 miters, see separate print approval
- Product should be installed per provided installation instructions

### PROJECT INFO

Project Name: \_\_\_\_\_

Architect: \_\_\_\_\_

Roofing Contractor: \_\_\_\_\_

#### Project Type:

By selecting this box you have verified and confirmed that dimensions, sizes, and quantities are correct. All products will be installed in strict accordance with printed instructions.

Date: \_\_\_\_\_

#### Hickman Edge Systems

4 Commerce Way  
Arden, NC 28704  
Phone: 828-676-1700  
www.hickmanedgesystems.com

SHT# 1 of 1

DATE: 11/29/21

DRN BY: JJC

CKD BY: MM

DWG #: 64012-37332

REV: A

### DIMENSIONS

Fill out additional information on the drawing above.

GUTTER DIAMETER	A	B	C	D
<input type="checkbox"/> 5"	2 1/2"	5 1/4"	3"	2 1/2" Radius
<input type="checkbox"/> 6"	3"	6 1/4"	3 1/2"	3" Radius
<input type="checkbox"/> 7"	3 1/2"	7 1/4"	4"	3 1/2" Radius
<input type="checkbox"/> 8"	4"	8 1/4"	4 1/2"	4" Radius
<input type="checkbox"/> 9"	4 1/2"	9 1/4"	5"	4 1/2" Radius
<input type="checkbox"/> 10"	5"	10 1/4"	5 1/2"	5" Radius

### MATERIAL

- 24 Ga. Galv. Steel      Color: \_\_\_\_\_
- 22 Ga. Galv. Steel      Finish: \_\_\_\_\_
- .040" Aluminum
- .050" Aluminum
- .063" Aluminum
- OTHER: \_\_\_\_\_
- Substrate:  Wood  
If substrate is not given, wood fasteners will be provided.  Masonry  
 Metal

### QUANTITIES

\_\_\_\_\_ Lineal Feet (10"-0" Lengths)

\_\_\_\_\_ Outside Miter (90°)

\_\_\_\_\_ Inside Miter (90°)

\_\_\_\_\_ Right Endcaps

\_\_\_\_\_ Left Endcaps

\_\_\_\_\_ Expansion Joints

Accessory Type\*:      Quicklock (Default)      Welded (Surcharge)

NOTE: ONE EXPANSION JOINT INCLUDES: (2) ENDCAPS, (1) OUTSIDE COVER PLATE AND (1) TOP PLATE