

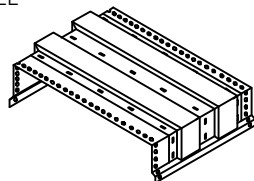

VERSITRIM CANTILEVER COPING

DOUBLE CANTILEVER VERSION

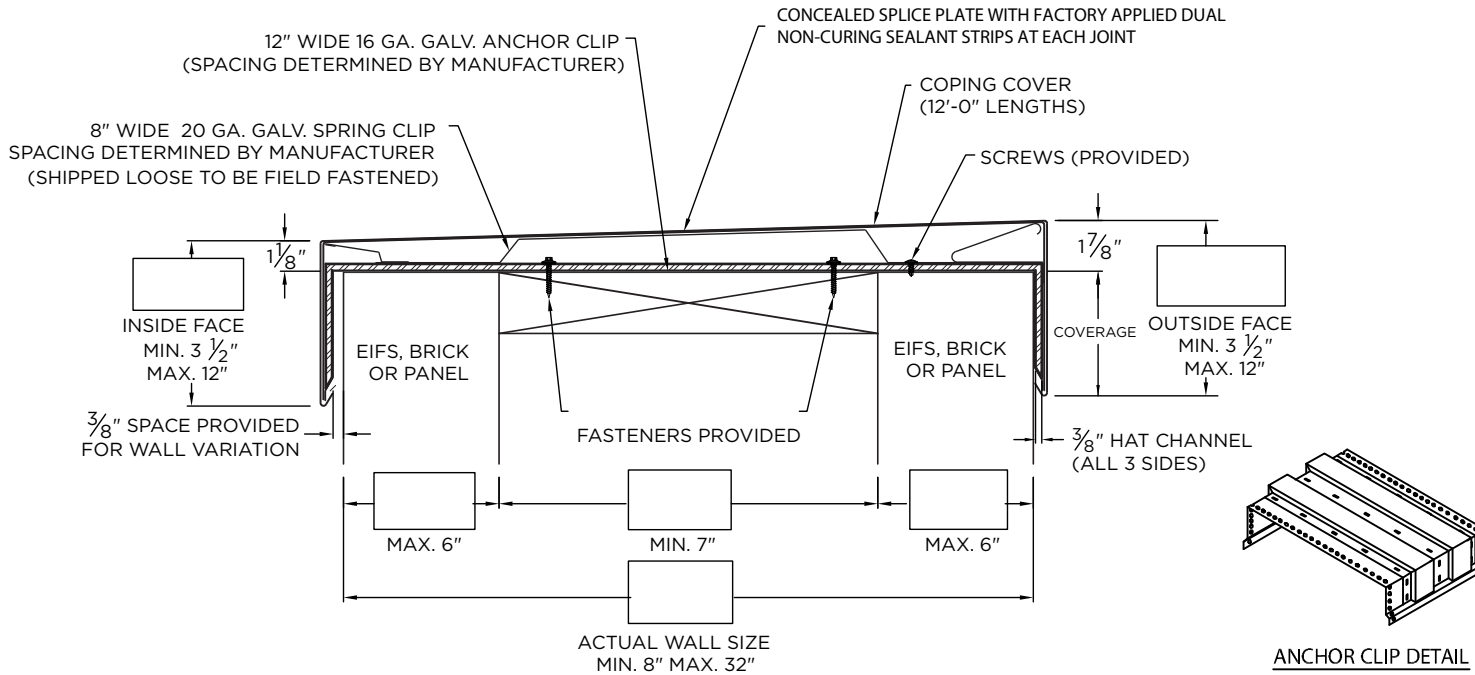

ANCHOR CLIP DETAIL

* NOTES

- 24 ga. Galv. and .040" Alum. Coping covers available for wall sizes 8" to 24" ONLY
- Oil canning can occur on larger face heights; recommend 22 ga., .050" or .063" for face height over 8"
- Unless otherwise noted, fabrication of miters and accessories are furnished standard utilizing a non-penetrating quicklock joint, then factory sealed watertight.
- Welded accessories require a minimum material thickness of .050"
- For non-90 miters, see separate print approval
- Product should be installed per provided installation instructions

PROJECT INFO

Project Name: _____

Architect: _____

Roofing Contractor: _____

Project Type:

By selecting this box you have verified and confirmed that dimensions, sizes, and quantities are correct. All products will be installed in strict accordance with printed instructions.

Date: _____

Customer Service
800-558-2162
(Metal-Era)

SHT #: _____ of _____

DATE: **09/19/24**

DRN BY: **JJC**

CKD BY: **MM**

DWG #: **18011-23702**

REV: **C**

MATERIAL*

- | | |
|---|---|
| <input type="checkbox"/> 24 Ga. Galv. Steel | Color: _____ |
| <input type="checkbox"/> 22 Ga. Galv. Steel | Finish: _____ |
| <input type="checkbox"/> .040" Aluminum | Substrate: |
| <input type="checkbox"/> .050" Aluminum | if substrate is not given, wood fasteners will be provided. |
| <input type="checkbox"/> .063" Aluminum | <input type="checkbox"/> Wood |
| <input type="checkbox"/> OTHER: _____ | <input type="checkbox"/> Masonry |
| | <input type="checkbox"/> Metal |

QUANTITIES

_____ Lineal Feet (12'-0" Lengths)

_____ Outside Miter (90°)

_____ Inside Miter (90°)

_____ Right Endcaps

_____ Left Endcaps

Accessory Type* : Quicklock (Default) Welded (Surcharge)

_____ Right Endwall Flashing (Coping Version)

_____ Left Endwall Flashing (Coping Version)

_____ Right Endwall Flashing (Splice Plate Version)

_____ Left Endwall Flashing (Splice Plate Version)

VERSITRIM CANTILEVER COPING

DOUBLE CANTILEVER VERSION

STANDARD ACCESSORIES

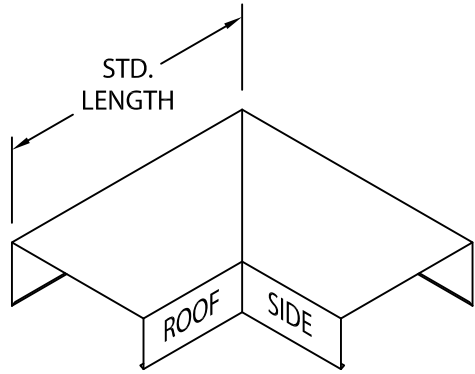

OUTSIDE MITER

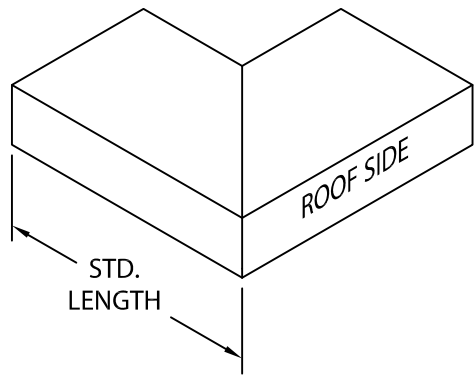

INSIDE MITER

MITER STANDARD LEG LENGTH:
WALL SIZE + 10 3/8" = LENGTH

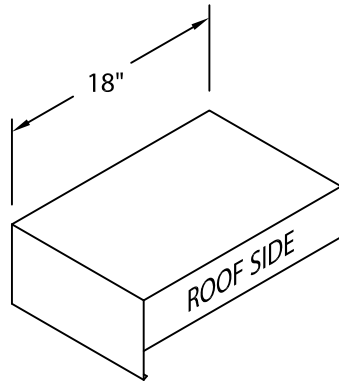

ENDCAP
(LEFT HAND SHOWN)

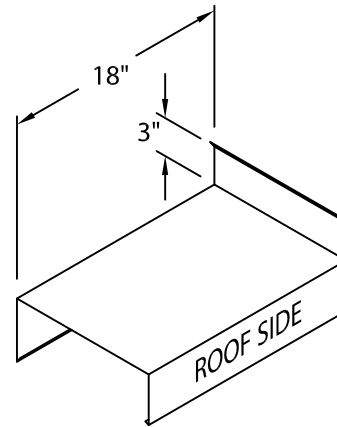

ENDWALL FLASHING
COPING VERSION
(RIGHT HAND SHOWN)

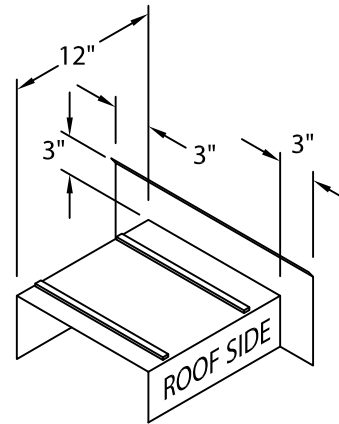

ENDWALL FLASHING
SPLICE PLATE VERSION
(RIGHT HAND SHOWN)
(AVAILABLE ONLY IN
.040" WELDED, PAINTED
TO MATCH COPING)

NOTES

Additional accessories are available including:

- Transition Miters
- Straight Transition Miters
- "T" Miters
- "Z" Miters
- Step-up Miters
- Peak / Valley Miters
- Pilaster Caps
- Radius Coping

For additional accessory requirements, attach sketches or call manufacturer for assistance.

SHT #: ____ of ____

DATE: **09/19/24**

DRN BY: **JJC**

CKD BY: **MM**

DWG #: **18011-23702**

REV: **C**

Customer Service
800-558-2162
(Metal-Era)