

TERMINEDGE ONE FASCIA

FULLY ADHERED OR MECHANICALLY ATTACHED SINGLE-PLY VERSION

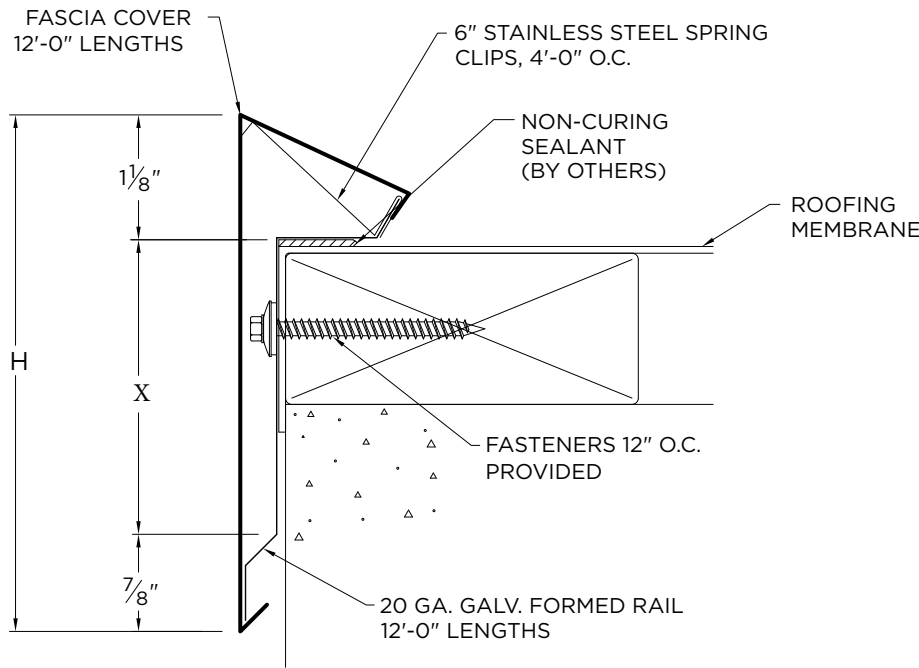

NOTES

- Lap joint provided with 24 ga. 22 ga. .040"
- Splice plate provided with .050" and .063"
- Rail miters are not provided (cover only)
- For non-90 miters, see separate print approval
- Product should be installed per provided installation instructions
- ANSI/SPRI/FM 4435/ES-1 Test Pressure up to 396 psf (24 ga., 22 ga., .040")

APPROVALS



ANSI/SPRI/FM 4435/ES-1
Test Pressures listed in notes

PROJECT INFO

Project Name: _____

Architect: _____

Roofing Contractor: _____

Project Type:

By selecting this box you have verified and confirmed that dimensions, sizes, and quantities are correct. All products will be installed in strict accordance with printed instructions.

Date: _____

Hickman Edge Systems

4 Commerce Way
Arden, NC 28704
Phone: 828-676-1700
www.hickmanedgesystems.com

SHT# 1 of 1

DATE: 10/25/21

DRN BY: JJC

CKD BY: MM

DWG #: 64010-36622

REV: A

DIMENSIONS

PRODUCT ID. NO.	H DIM	X DIM	NAILER COVERAGE
<input type="checkbox"/> ESE-S40	4"	2"	1 NAILER
<input type="checkbox"/> ESE-S50	5"	3"	2 NAILERS
<input type="checkbox"/> ESE-S65	6 1/2"	4 1/2"	3 NAILERS
<input type="checkbox"/> ESE-S80	8"	6"	4 NAILERS

MATERIAL

- 24 Ga. Galv. Steel
- 22 Ga. Galv. Steel
- .040" Aluminum
- .050" Aluminum
- .063" Aluminum
- OTHER: _____

Color: _____

Finish: _____

Substrate: Wood
 Masonry
 Metal
If substrate is not given, wood fasteners will be provided.

QUANTITIES

_____ Lineal Feet (12'-0" Lengths)

_____ Outside Miter (90°) (Cover Only)

_____ Inside Miter (90°) (Cover Only)