



TERMINEDGE XT MB FASCIA

BUILT-UP OR MODIFIED VERSION

INSTALLATION INSTRUCTIONS

For Use With Modified Roof Systems

1. Roof Membrane

Follow the general recommendations of the roofing membrane manufacturer for membrane treatment at the roof edge. Position modified membrane over the roof edge and down the outside face as shown.

IMPORTANT! Outside edge of treated wood nailer(s) (minimum 2 x 4) shall be aligned flush with outermost edge of wall. Fascia is for use as a perimeter securement on roof designs where the product is not installed in a waterline.

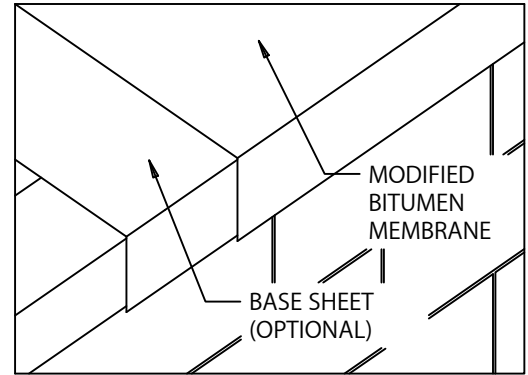

NOTE: Some manufacturers may require a "sacrificial" flashing strip. (Refer to drawing 2A & 2B) Please check with membrane manufacturer prior to installation.

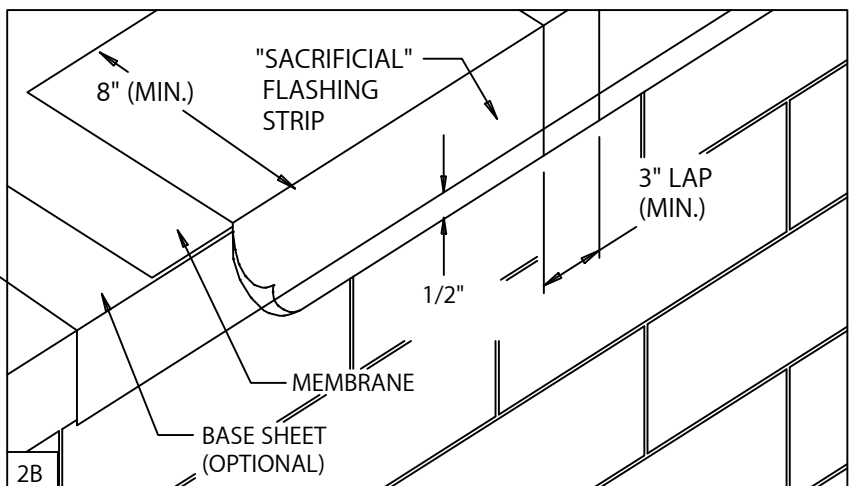
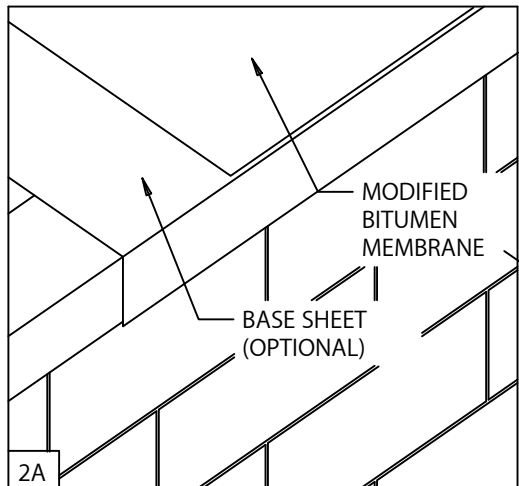

2. Roof Edge

Install "sacrificial" flashing strips according to membrane manufacturers recommendations. Install the largest manageable lengths possible to minimize overlaps under the anchor bar. Following the applicable flashing method (hot mop, cold adhesive, etc..) according to the manufacturer's recommendations, lay the flashing strip into place extending a minimum 8" onto the roof membrane and down the outside face of wall, 1/2" beyond the wood nailer.

NOTE: In cold weather, the back of flashing strip should be treated appropriately and shorter lengths of flashing strips should be used.



TERMINEDGE XT MB FASCIA

BUILT-UP OR MODIFIED VERSION

For Use with Built-Up Roof Systems

1. Roof Membrane

Prior to the application of the Fascia, it is suggested that the contractor follow the common recommended industry practice of installing an "envelope" over the ends of the base or B.U.R. plies. As always, follow the general recommendations of the roofing membrane manufacturer for membrane treatment at the roof edge.

IMPORTANT! Outside edge of treated wood nailer(s) (minimum 2 x 4) shall be aligned flush with outermost edge of wall. Fascia is for use as a perimeter securement on roof designs where the product is not installed in a waterline.

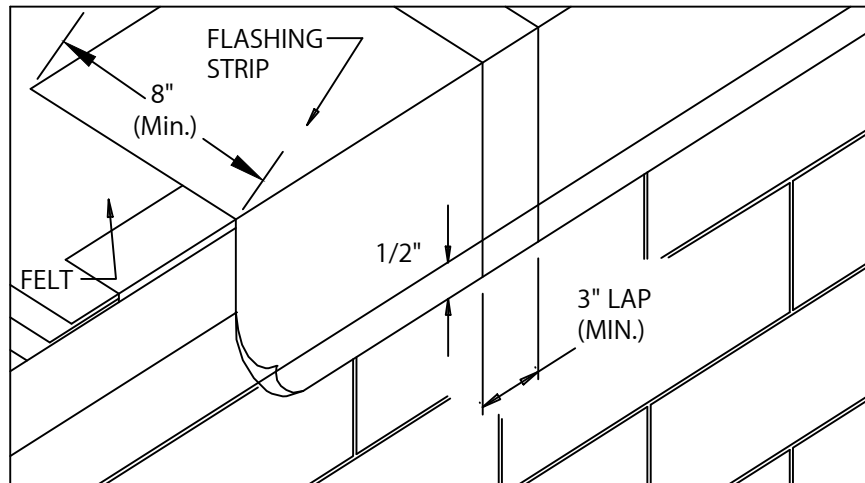
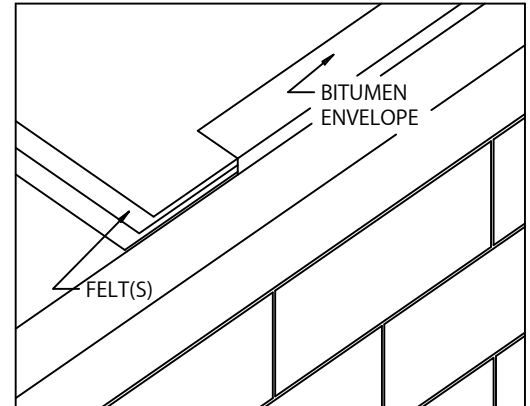

2. Roof Edge

Cut flashing strip into the longest possible sections manageable to minimize laps at the edge. Starting at outside edge, mop surface of felts out onto the roof membrane with Type III or IV asphalt. Lay the flashing strip into place over the roof edge extending 1/2" below nailer and onto the roof membrane a minimum of 8". The sheet should be "worked-in" to ensure that it is firmly and uniformly bonded. In cool or cold weather, the back of flashing strip should also be mopped with the hot bitumen, and shorter lengths of flashing strips should be used. Laps in the flashing strip should be a minimum of 3" and well sealed.

NOTE! Flashing strip is material used in construction of traditional flashing systems on built-up roofs. It readily conforms to transitions at the outside edge and wall area. (Follow general recommendations of the roofing membrane manufacturer.)



TERMINEDGE XT MB FASCIA

BUILT-UP OR MODIFIED VERSION

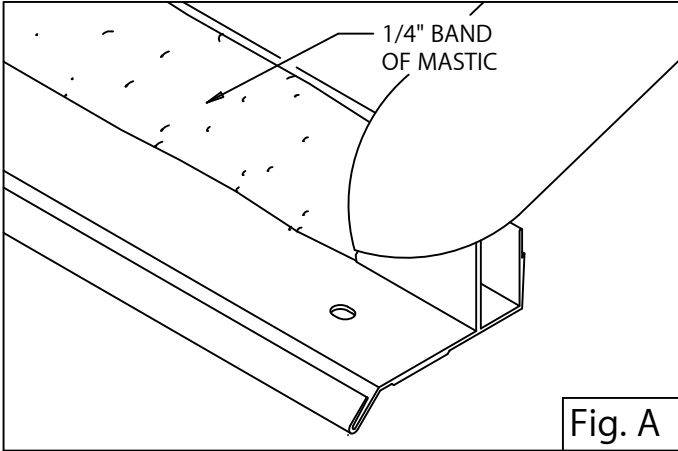

Fig. A

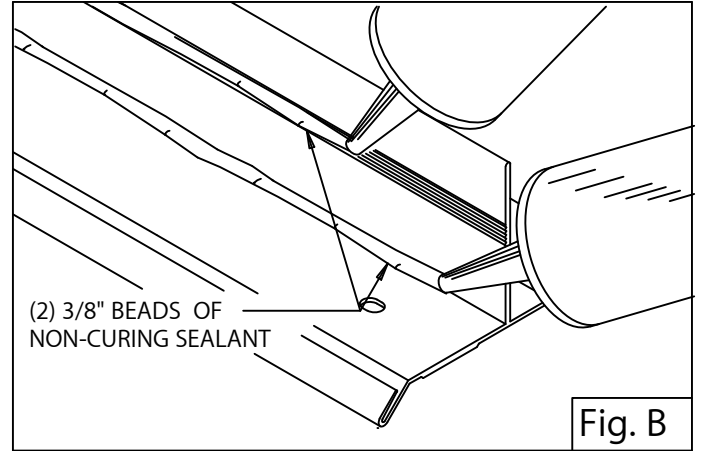
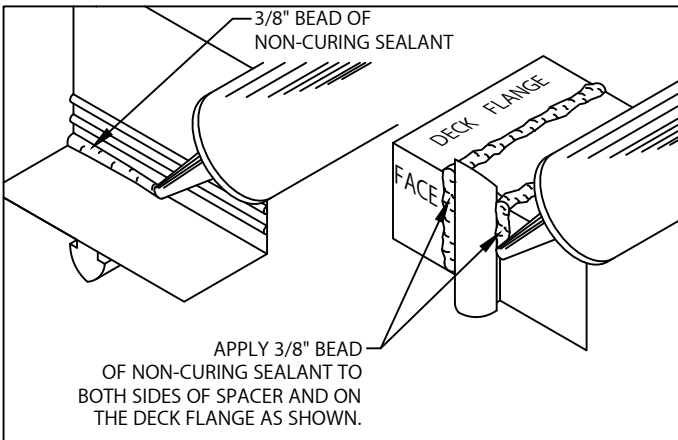

Fig. B

3. Miter & Scupper Anchor Bar (Preparation)

Lay miters and scuppers on deck with outside face down. Be sure aluminum anchor bar is clean and free of dirt or dust. Refer to Fig. A or B, depending on roofing manufacturer's recommendations. For Fig. A, Apply a 3" wide 1/4" thick band of mastic to the back of the anchor bar as shown. For Fig. B Apply a heavy 3/8" bead of non-curing sealant to the back of anchor bar as shown. Application of either type of mastic or sealant is required along the full length of each miter anchor bar.

OPTIONAL INSTALL



4. Anchor Bar Splice Plates

Apply sealant to each splice plate as shown and as described in STEP 3. Ensure the sealant is placed into the grooves along the spacer.

CAUTION! Installers shall wear protective eyewear to prevent injury. Do not over-drive fasteners, as stripping can occur at high driver torque. Recommended driving tool: 600-800 rpm electric drill equipped with depth-sensing nosepiece to prevent over-driving and stripout.

Do not use impact type tool.

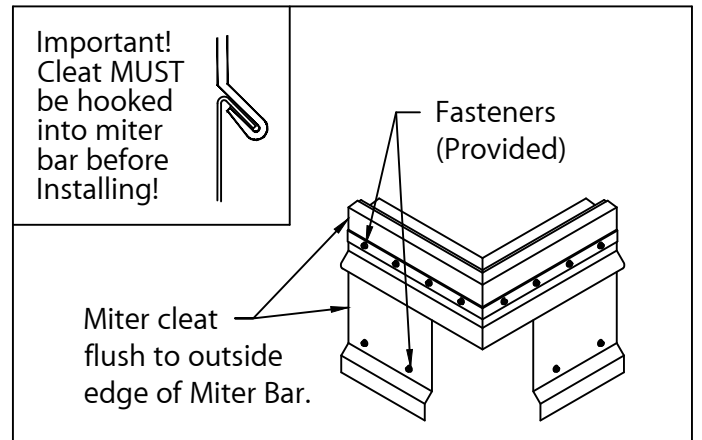

5. Miter Bar & Miter Cleat Installation

Hook miter cleat pieces to miter bar. Flush ends of miter cleat piece and miter bar. Install miter assembly with one anchor bar splice plate under each end of miter bar, anchor bar must insert into the grooves of the anchor bar splice plate. Fasteners and driver bits provided by manufacturer. Fasten the miter bar and miter cleat using provided fasteners. Next locate and install scuppers with sealant, fasteners and anchor bar splice plates.



TERMINEDGE XT MB FASCIA

BUILT-UP OR MODIFIED VERSION

IMPORTANT! Be sure to remove protective plastic film prior to installing each fascia section.

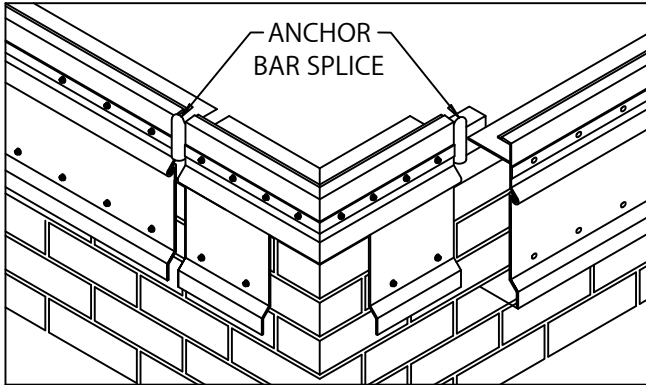

6. Anchor Bar & Cleat Installation

Hook anchor cleat to anchor bar as shown in step 5. Position 12' anchor bar/cleat sections with applied non-curing sealant as shown in step 3, overlapping anchor bar splice plate. Allow $\frac{3}{8}$ " space between anchor bars. Install anchor bar splice plate at other end of bar/cleat section. Fasten anchor bar 12" O.C. through slotted holes using provided fasteners. Fasten anchor cleat 24" through slotted holes using provided fasteners. The anchor bars must insert into the grooves of the anchor bar splice plates. Field cut sections as necessary.

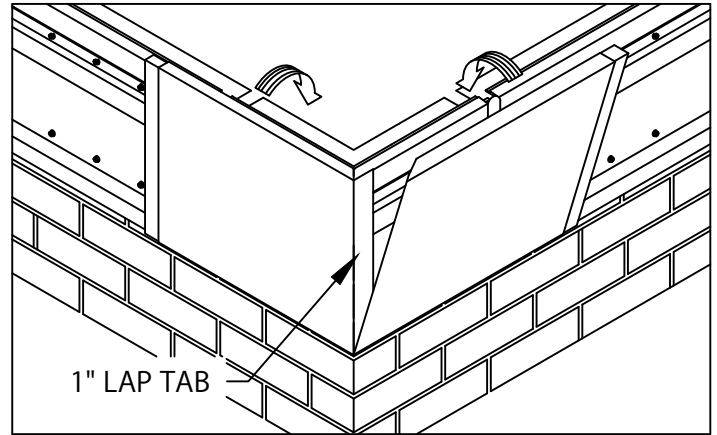

7. Fascia Miter Covers

Install miter covers first. Insert one splice plate under each end of the two piece miter cover. Engage cover with 90° tab onto bottom of anchor bar and rotate miter cover up and over anchor bar until engaged along entire length of the anchor bar. Repeat steps to install miter cover without the 90° tab.

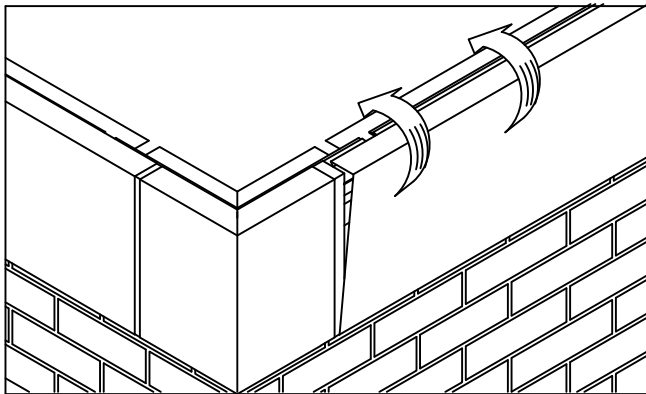

8. Fascia Covers

Install 12'-0" fascia cover sections. Allow a $\frac{3}{8}$ " gap between fascia cover sections. Insert one splice plate under far end of each fascia cover section. Install cover by hooking lower edge of cover onto Anchor cleat and rotating cover up and over Anchor bar until engaged along entire length of cover section. Continue to install cover sections in this manner, field cutting where necessary using a fine tooth hacksaw.

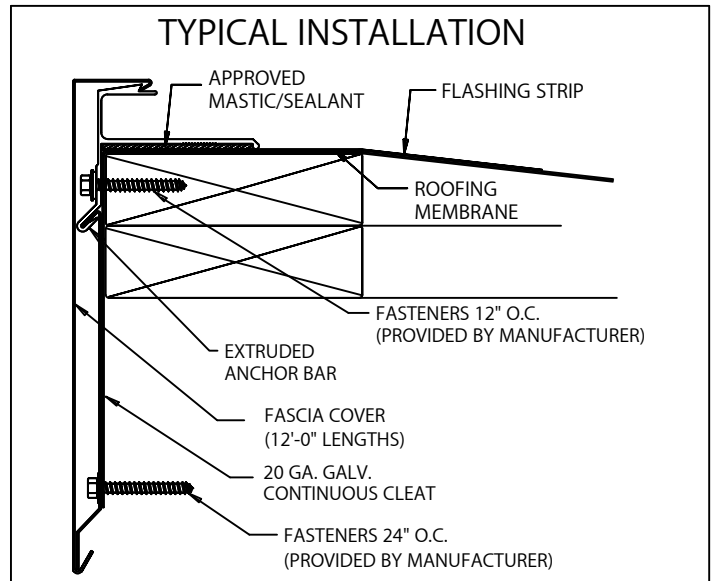

U.S. Patent # 7,451,572

IMPORTANT! Be sure to remove protective film prior to installing each fascia section.

DIAGONAL SLOT ANCHOR BAR INSTALLATION

NOTE: IF THE SLOTS ON THE ANCHOR BAR ARE ALL HORIZONTAL, NOT DIAGONAL, FASTEN IN THE CENTER OF THE SLOT

PLACE FASTENER AT TOP OF SLOT FOR SINGLE NAILER INSTALLATION

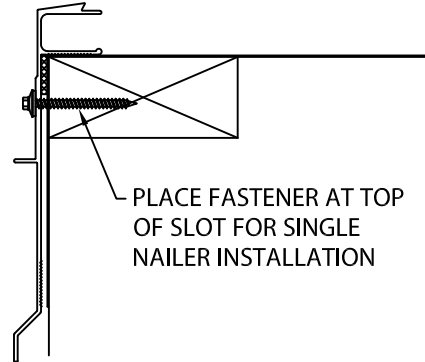

PLACE FASTENER AT BOTTOM OF SLOT IF 1/2" COVER BOARD IS USED

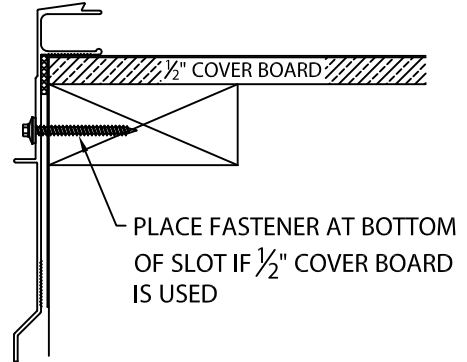

PLACE FASTENER AT BOTTOM OF SLOT IF FASTENING INTO MASONRY

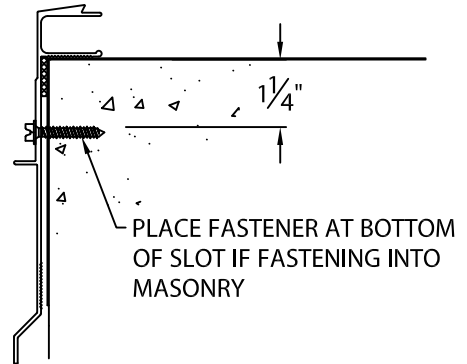

PLACE FASTENER AT BOTTOM OF SLOT IF FASTENING INTO ELIMINAILER-T

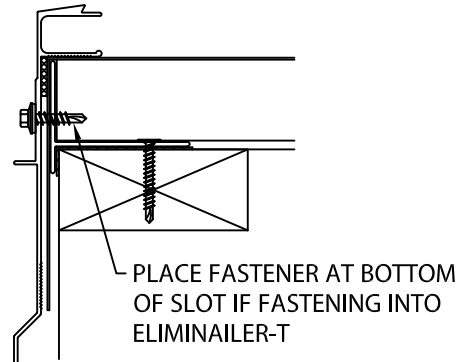



TERMINEDGE XT MB FASCIA

BUILT-UP OR MODIFIED VERSION

COMPONENT LIST

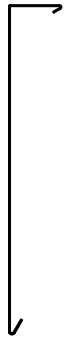

Fascia Cover
12'-0" Lengths

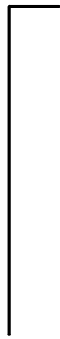

Cover Splice Plate
3 1/2" Wide

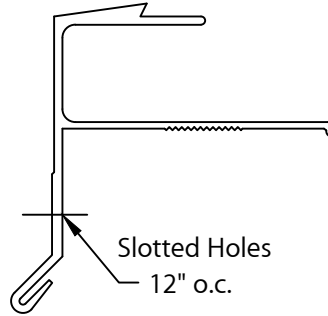

Extruded Anchor Bar
12'-0" Lengths

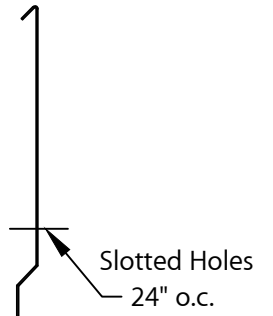

Continuous Anchor Cleat
12'-0" Lengths

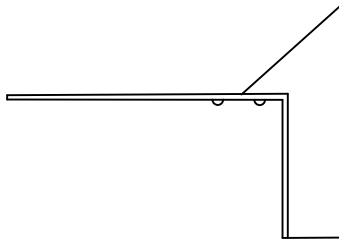

Anchor Bar Splice
3 1/2" Wide w/ 3/4" EPDM Gasket

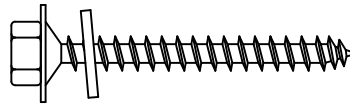

Fastener W / Washer
for installing Anchor Bar

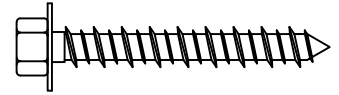

Fastener W / Washer
for installing Anchor Cleat

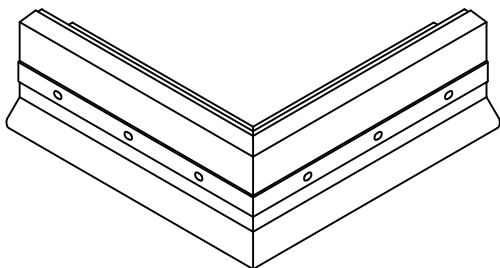

Anchor Bar Miter
Outside

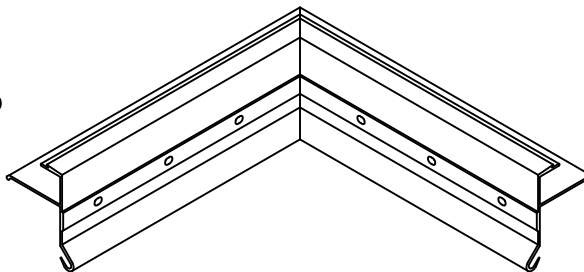

Anchor Bar Miter
Inside



Anchor Cleat for Miters
(2) 14" Long pcs. per miter

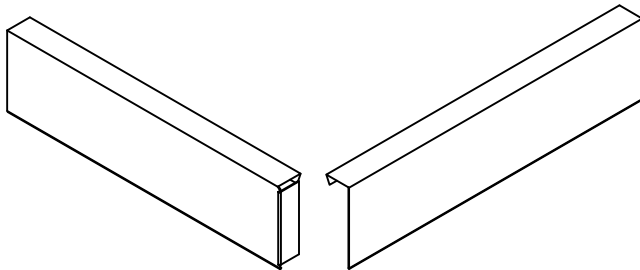

Outside Miter
Cover With Tab

Outside Miter
Cover Without Tab

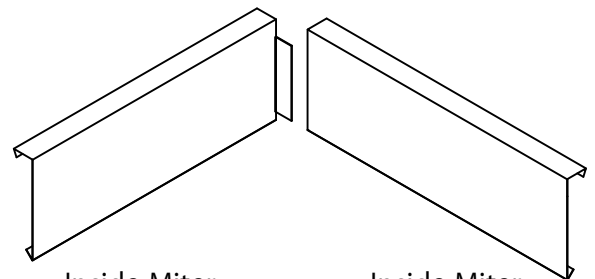

Inside Miter
Cover With Tab

Inside Miter
Cover Without Tab