

# CREATIVE DESIGN CORNICE COPING

3'-0" O.C.

## INSTALLATION INSTRUCTIONS

**IMPORTANT:** Prior to installation, read instructions carefully.

**NOTE:** Position roof membrane on top of the wall covering the treated wood nailer(s) or substrate completely. Allow 1/2" minimum excess membrane beyond nailer where applicable. NRCA requirement. Not shown for clarity.

**CAUTION:** INSTALL MITERS FIRST!

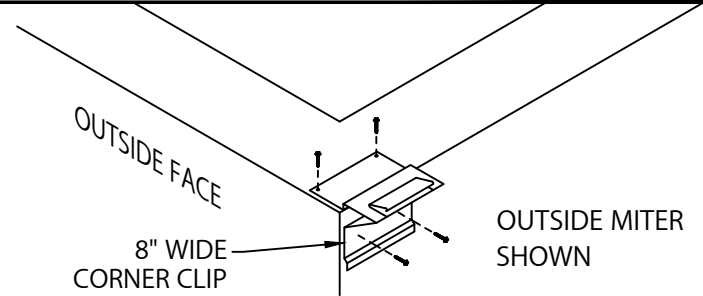

**STEP 1 - CORNER SUPPORT CLIPS**  
LOCATE AND FASTEN ONE 8" WIDE GALVANIZED CORNER SUPPORT CLIP TO ONE SIDE OF WALL.

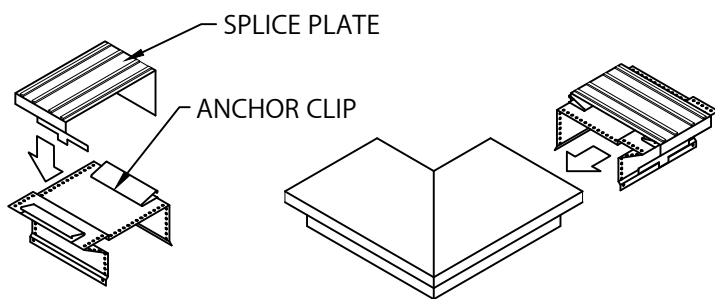

**STEP 2 - MITER SPLICE PLATES & ANCHOR CLIPS**  
POSITION THE SPLICE PLATE IN THE CENTER OF THE ANCHOR CLIP. INSTALL THE SPLICE PLATE AND ANCHOR CLIP ASSEMBLY HALFWAY INTO EACH END OF THE CORNER AS SHOWN.

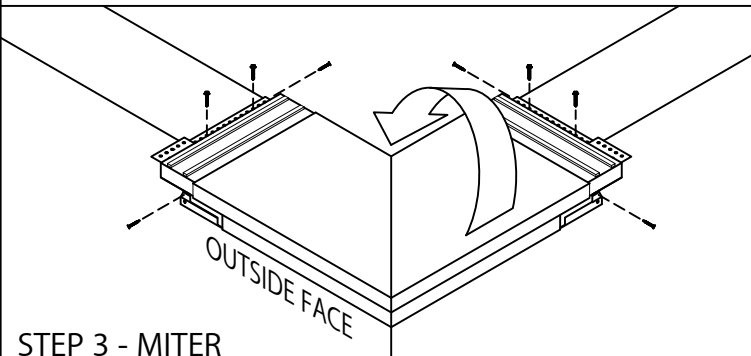

**STEP 3 - MITER**  
HOOK OUTSIDE FACE OF MITER ASSEMBLY ONTO CORNER CLIP AND ROTATE INTO PLACE. SECURE AT THE EXPOSED EDGE OF THE ANCHOR CLIP AS PER DETAIL A.

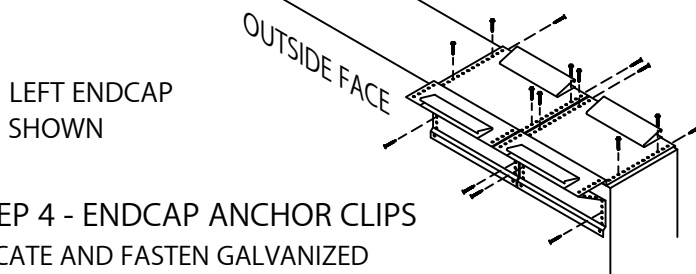

**STEP 4 - ENDCAP ANCHOR CLIPS**  
LOCATE AND FASTEN GALVANIZED ANCHOR CLIPS TO WALL WITH PROVIDED FASTENERS FOR SUBSTRATE (SEE DETAIL A).

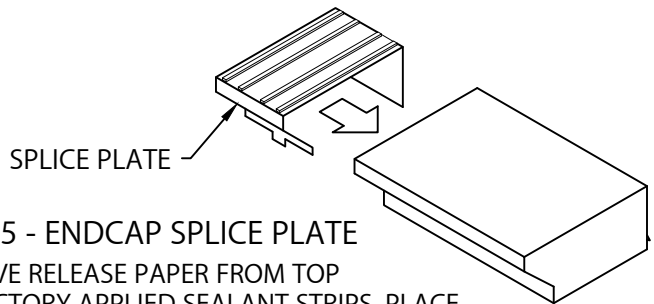

**STEP 5 - ENDCAP SPLICE PLATE**  
REMOVE RELEASE PAPER FROM TOP OF FACTORY APPLIED SEALANT STRIPS. PLACE SPLICE PLATE HALFWAY INTO ENDCAP AS SHOWN.

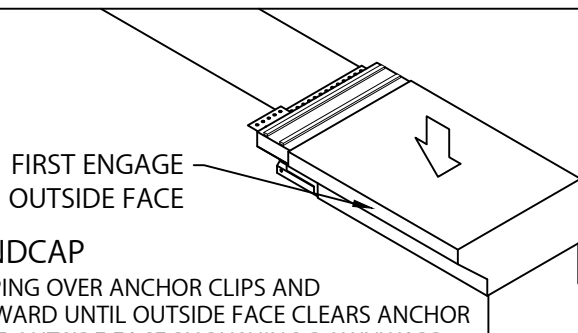

**STEP 6 - ENDCAP**  
POSITION COPING OVER ANCHOR CLIPS AND PRESS DOWNWARD UNTIL OUTSIDE FACE CLEARS ANCHOR CLIPS. ENGAGE OUTSIDE FACE BY PUSHING DOWNWARD ON FRONT EDGE UNTIL SNAP LOCK OCCURS. THEN ENGAGE INSIDE FACE BY PUSHING DOWNWARD ON BACK EDGE UNTIL SNAP LOCK OCCURS.

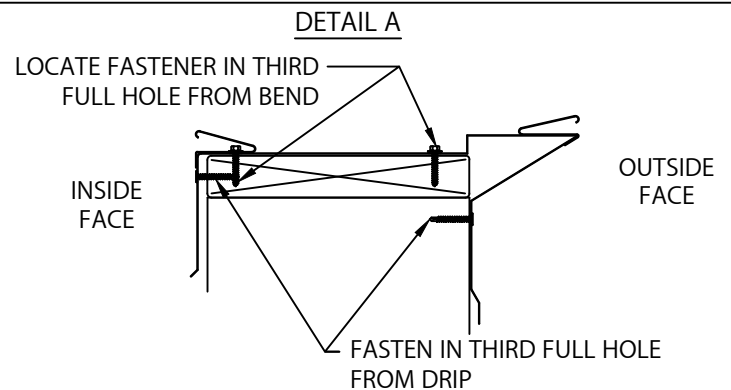

# CREATIVE DESIGN CORNICE COPING

3'-0" O.C.

## INSTALLATION INSTRUCTIONS

### INSTALLATION NOTES:

1) Installing contractor shall check as-built conditions, including nailer attachment, and verify the manufacturer's coping details for accuracy to fit the wall assembly prior to fabrication.

2) Fasteners must be corrosion resistant and rated for a minimum 250# pullout force for the substrate that is being used.

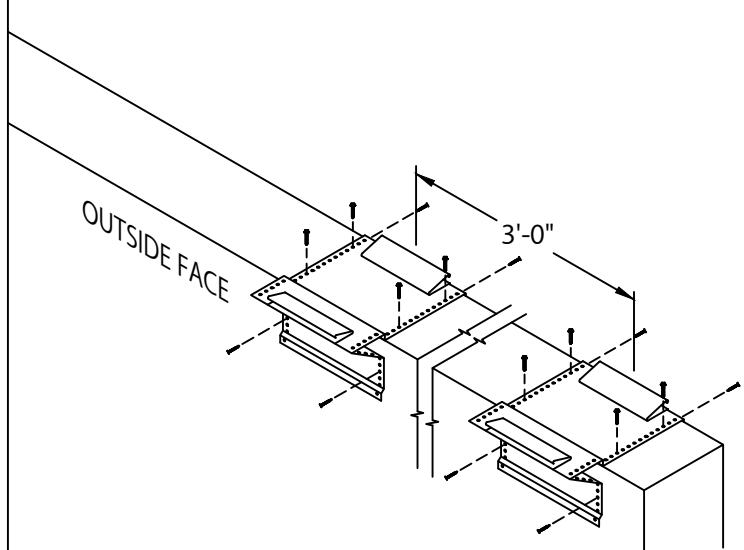
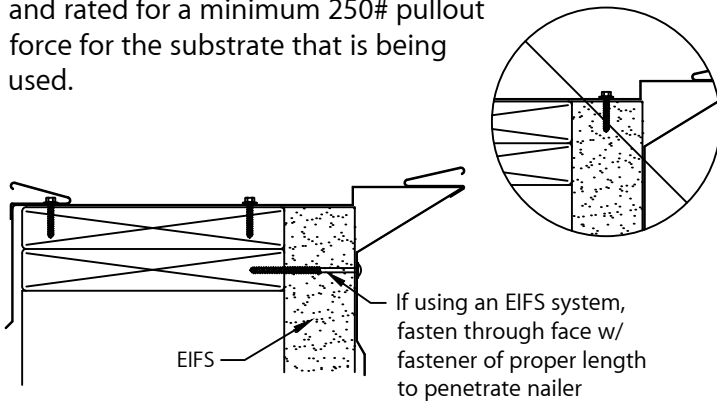

### STEP 7 - ANCHOR CLIPS

LOCATE AND FASTEN GALVANIZED ANCHOR CLIPS TO WALL AT 3'-0" CENTERS WITH PROVIDED FASTENERS FOR SUBSTRATE (SEE DETAIL A).

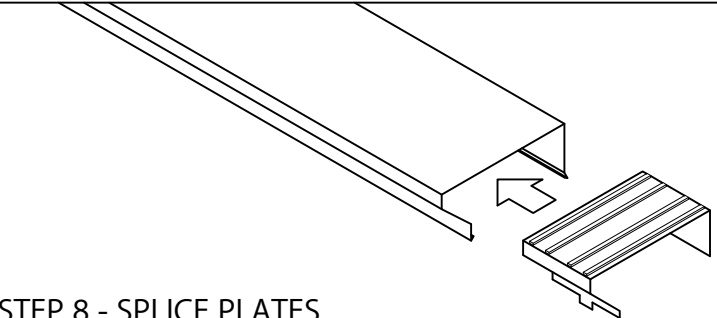

### STEP 8 - SPLICE PLATES

REMOVE RELEASE PAPER FROM TOP OF FACTORY APPLIED SEALANT STRIPS. PLACE SPLICE PLATE HALFWAY INTO ONE END OF 12'-0" LENGTH OF COPING AS SHOWN.

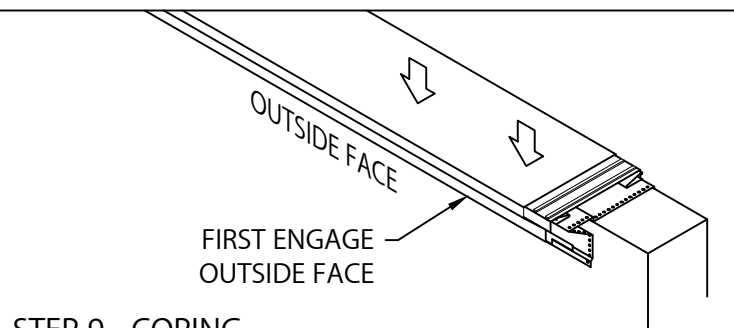

### STEP 9 - COPING

POSITION COPING OVER ANCHOR CLIPS AND PRESS DOWNWARD UNTIL OUTSIDE FACE CLEARS ANCHOR CLIPS. ENGAGE OUTSIDE FACE BY PUSHING DOWNWARD ON FRONT EDGE UNTIL SNAP LOCK OCCURS. THEN ENGAGE INSIDE FACE BY PUSHING DOWNWARD ON BACK EDGE UNTIL SNAP LOCK OCCURS.

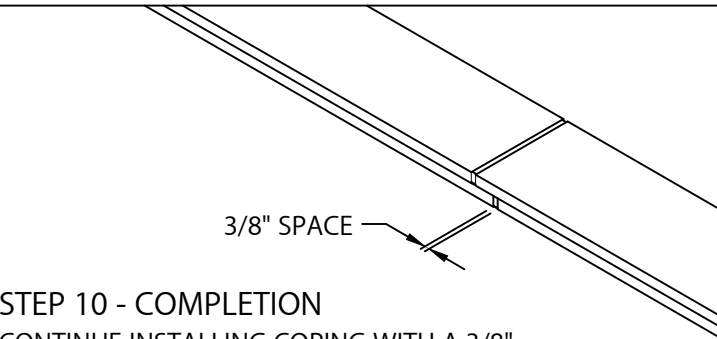

### STEP 10 - COMPLETION

CONTINUE INSTALLING COPING WITH A 3/8" SPACE AT SPLICE JOINTS TO ALLOW FOR THERMAL EXPANSION. FIELD CUT WHERE NECESSARY USING FINE TOOTH HACKSAW OR SNIPS. NOTE: REMOVE PROTECTIVE FILM IMMEDIATELY.

### TYPICAL INSTALLATION

