

Roofers Edge Fascia Snap-On Fascia

ORDER SPECIFICATION FORM

ANSI/SPRI/FM4435/ES-1 TEST PRESSURES UP TO 213 PSF (HORIZONTAL)

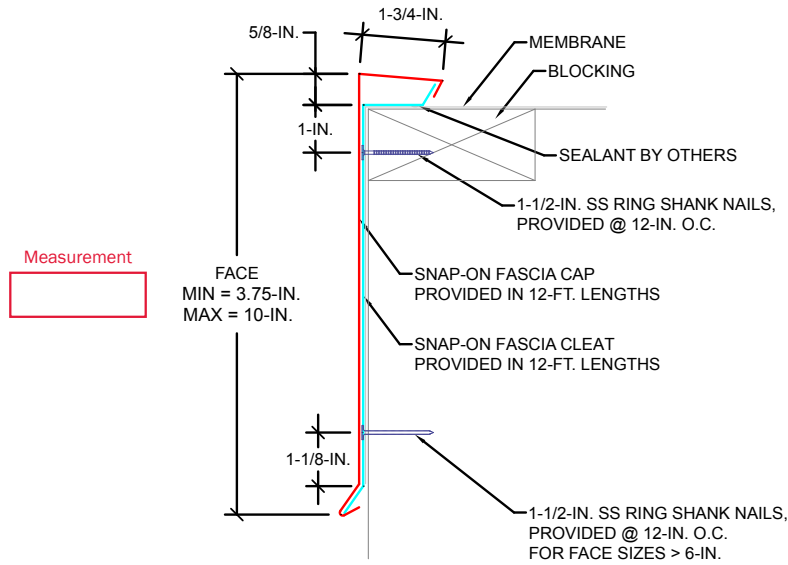

FOR MASONRY APPLICATIONS, PLEASE CONTACT US.
CONTACT US FOR APPROPRIATE RECOMMENDATIONS NEEDED TO MEET/EXCEED
ANSI/SPRI/FM4435/ES-1 DESIGN CRITERIA

QUANTITY			CUSTOMER APPROVAL		
Straight Length			Approved for Fabrication Approved with Changes Not Approved		
FACE HEIGHT		COLOR			
_____		_____			
COVER MATERIAL		THICKNESS	COVER FINISH		
Aluminum Galvanized Steel		24Ga. .040 in.	Mill Prefinished Kynar Premium Prefinished Kynar		
APPROVALS			Title _____ Date _____		
ANSI/SPRI/FM 4435 /ES-1 TESTED			Job Name: _____		
			Project Location: _____		
			Customer: _____		
			Representative: _____		